

PLAN VIEW

6" Non Traffic Lid (Wt: 9,800 lbs)
9" Traffic Lid (Wt: 12,200 lbs)

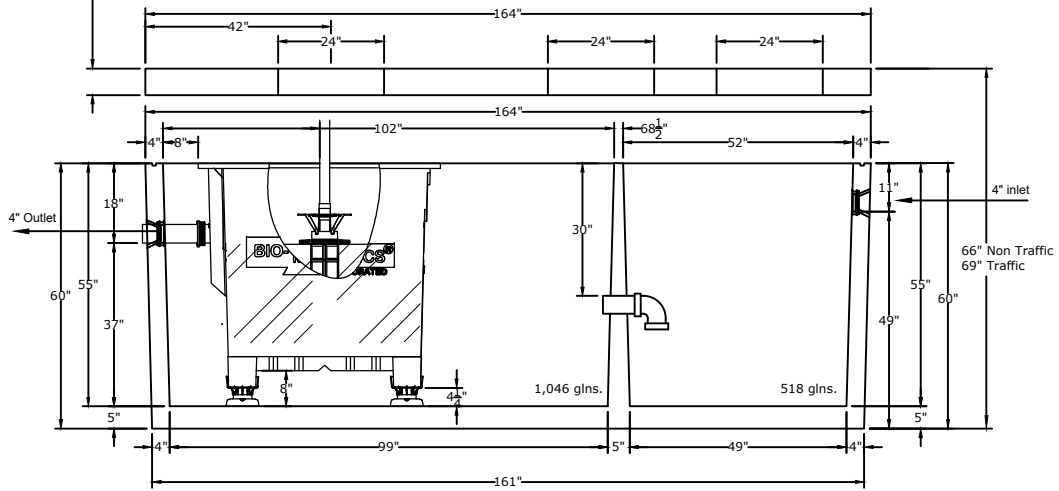

LONGITUDINAL SECTION

6" Non Traffic Lid
9" Traffic Lid

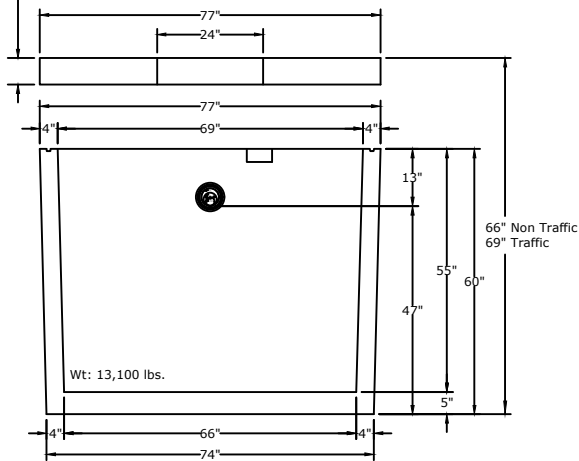

OUTLET ELEVATION

SEPTIC TANKS SPECIFICATIONS:

1. Material Specifications:
 - 1.1. Concrete: Portland Cement ASTM C 150 and Federal Specification on Cement, SS-C 1960/3, Type II/V Low Alkali. Minimum Compressive Strength 5,000 at 28 days.
 - 1.2. Reinforcing Bars: ASTM A-706 / A-615, Grade 40 and 60.
2. All dimensions + or -, not to be used for construction purposes unless certified.
3. Standard ground water seal-butyl mastic, cement mortar, epoxy, or polyurethane.
4. Inlet and Outlet fittings installed in tank walls using "Polylok Pipe Seal". Low pressure pipe seals for precast tanks.
5. Tank to be placed on natural / native soil or approved compact fill.



1625 E. DONOVAN RD., STE. C
SANTA MARIA, CA 93454
PH: (805) 928-2855
FAX: (805) 928-2114
www.midstateconcrete.com

2,000 GAL.
0.75 MicroFast TANK