

GENERAL

- THE CONTRACTOR SHALL ASSUME SOLE AND COMPLETE RESPONSIBILITY FOR THE JOB SITE CONDITIONS DURING THE COURSE OF CONSTRUCTION, INCLUDING THE SAFETY OF ALL PERSONS AND PROPERTY, AND THIS REQUIREMENT SHALL APPLY CONTINUOUSLY AND NOT BE LIMITED TO NORMAL WORKING HOURS.
- THE CONTRACTOR SHALL BE RESPONSIBLE FOR ALL MEANS AND METHODS OF CONSTRUCTION AND SHALL TAKE ALL MEASURES NECESSARY TO PROTECT THE STRUCTURE DURING CONSTRUCTION. INCLUDING, BUT NOT LIMITED TO, SHORING, BRACING, AND TEMPORARY EXCAVATIONS, AND SHALL BE IN ACCORDANCE WITH ALL STATE AND FEDERAL SAFETY REQUIREMENTS.
- THE CONTRACTOR SHALL VERIFY ALL DIMENSIONS, ELEVATIONS, AND SITE CONDITIONS BEFORE STARTING WORK AND SHALL NOTIFY THE ARCHITECT AND ENGINEER IMMEDIATELY OF ANY DISCREPANCIES.
- ALL OMISSIONS AND CONFLICTS BETWEEN THE VARIOUS ELEMENTS OF THE WORKING DRAWINGS AND/OR SPECIFICATIONS SHALL BE BROUGHT TO THE ATTENTION OF THE ARCHITECT AND ENGINEER BEFORE PROCEEDING WITH WORK SO INVOLVED.
- ANY CONFLICTS ON THE DRAWINGS MUST BE RESOLVED WITH THE ARCHITECT AND ENGINEER BEFORE PROCEEDING WITH CONSTRUCTION.
- THE CONTRACTOR SHALL DETERMINE THE LOCATION OF UTILITY SERVICES IN THE AREA TO BE EXCAVATED PRIOR TO BEGINNING EXCAVATION.
- NO PIPES, DUCTS, SLEEVES, CHASES, ETC. SHALL BE PLACED IN SLABS, BEAMS, OR WALLS UNLESS SPECIFICALLY SHOWN OR NOTED. NOR SHALL ANY STRUCTURAL MEMBER BE CUT FOR PIPES, DUCTS, OR OTHER ITEMS UNLESS OTHERWISE NOTED. CONTRACTOR SHALL OBTAIN PRIOR APPROVAL FOR INSTALLATION OF ANY ADDITIONAL PIPES, DUCTS, OR OTHER ITEMS. REFER TO ARCHITECTURAL AND MECHANICAL DRAWINGS FOR LOCATIONS.
- ALL MATERIAL AND WORKMANSHIP SHALL CONFORM TO THE REQUIREMENTS OF THE LATEST EDITION OF THE LOCAL BUILDING CODE AND SHALL COMPLY WITH AND BE INSTALLED IN ACCORDANCE WITH ALL THE REQUIREMENTS OF ALL LEGALLY CONSTITUTED PUBLIC AUTHORITIES HAVING JURISDICTION, INCLUDING ALL COUNTY AND LOCAL ORDINANCES, AND THE SAFETY ORDERS OF THE STATE INDUSTRIAL ACCIDENT COMMISSION, OSHA.
- WHERE A SECTION OR TYPICAL DETAIL IS SHOWN FOR ONE CONDITION IT SHALL APPLY FOR ALL LIKE OR SIMILAR CONDITIONS UNLESS OTHERWISE NOTED.
- NO CHANGES ARE TO BE MADE TO THESE PLANS WITHOUT THE KNOWLEDGE AND WRITTEN CONSENT OF MST MANUFACTURING, LLC.
- ANY REFERENCE TO THE WORDS APPROVED, OR APPROVAL IN THESE DOCUMENTS SHALL BE HERE DEFINED TO MEAN GENERAL ACCEPTANCE OR REVIEW AND SHALL NOT RELIEVE THE CONTRACTOR AND/OR HIS SUB-CONTRACTORS OF ANY LIABILITY IN FURNISHING THE REQUIRED MATERIALS OR LABOR SPECIFIED.
- CONCRETE SLAB-ON-GRADE HAS NOT BEEN DESIGNED FOR CONSTRUCTION LOADS OR SPECIFIC OCCUPANT SERVICE LOADS BY THE STRUCTURAL ENGINEER.
- VIBRATIONAL EFFECTS OF MECHANICAL EQUIPMENT HAVE NOT BEEN CONSIDERED BY THE STRUCTURAL ENGINEER.
- THIS SHEET AND SUBSEQUENT DRAWINGS CONTAIN MANUFACTURER'S MINIMUM RECOMMENDATIONS ONLY. SPECIFICATIONS OF PROJECT STRUCTURAL ENGINEER SUPERCEDE THESE RECOMMENDATIONS.
- SEE ENGINEER AND/OR ARCHITECT'S SPECIFICATIONS AND ADDITIONAL REQUIREMENTS.OBSERVATION VISITS TO THE SITE BY THE STRUCTURAL ENGINEER SHALL NOT INCLUDE OBSERVATION OF SAFETY METHODS, BRACING, OR SUPPORT AND SHALL NOT BE CONSTRUED AS INSPECTION NOR APPROVAL OF CONSTRUCTION.

INSTALLATION INSTRUCTIONS

INSTALLATION NOTES BELOW ARE A SUMMARY. REFER TO INSTALLATION MANUAL FOR ADDITIONAL REQUIREMENTS FOR PROPER TANK INSTALLATION

- ALL TANKS MUST BE VISUALLY INSPECTED IN THE FIELD TO ENSURE NO DAMAGE HAS OCCURRED FROM SHIPPING AND HANDLING.
- IN ADDITION TO THE MANUFACTURER'S INSTRUCTIONS, THE INSTALLATION MUST COMPLY WITH ALL APPLICABLE BUILDING CODES.
- SHIP TANKS ON SUPPORT SADDLES PROVIDED.
- PLACE SADDLES NEAR EACH END OF TANK, DISTRIBUTING WEIGHT EVENLY.
- MOVE TANKS BY LIFTING, USING LIFTING LUGS PROVIDED. DO NOT REMOVE TANKS BY DRAGGING OR ROLLING OFF OF CARRIER. USE DOUBLE SLING WITH A MINIMUM OF 8" OF CABLE ON EACH SIDE FOR LIFTING. PLACE TANKS ON GROUND USING SADDLES PROVIDED, AND CHOCK BOTH SIDES OF TANK TO ENSURE IT WILL NOT ROLL IN WINDY CONDITIONS.
- RECOMMENDED LIFTING EQUIPMENT:
 - EXCAVATION EQUIPMENT THAT IS CAPABLE OF PRODUCING A LEVEL BOTTOM HOLE AND CAN PLACE BACKFILL MATERIAL AT ALL POINTS OF THE EXCAVATION
 - CRANE AND OR LIFTING EQUIPMENT THAT IS CAPABLE OF LIFTING AND PLACING TANKS AND ANCHORING DEVICES
 - TAPE MEASURE
 - SPIRIT LEVEL OR TRANSIT
 - TAMPING ROD
 - HAND SHOVELS
 - 8' LIFTING CHAIN OR SLING WITH HOOK ENDS. LARGER TANKS REQUIRE USE OF SPREADER BAR
 - SOIL COMPACTING EQUIPMENT.
- VISUAL INSPECTION:
 - ALL TANKS SHALL BE VISUALLY INSPECTED OVER THE ENTIRE VESSEL, PAYING PARTICULAR ATTENTION TO LOCATION OF SHIPPING CRADLES AND STRAPPING. INSPECT FOR THE FOLLOWING DEFECTS:
 - VISIBLE FRACTURES IN THE WALL OR RIBS.
 - DELAMINATING.
 - SCRATCHES, ABRASIONS, OR GAUGES EXTENDING MORE THAN 1/16" INTO THE LAMINATE OF THE FIBERGLASS.
 - STRESS CRACKS (FINE SPIDER LIKE CRACKS DEEP INTO THE STRUCTURE).
- IF ANY DAMAGE IS PRESENT, THE TANK SHALL NOT BE INSTALLED UNTIL IT IS INSPECTED AND REPAIRED BY AN AUTHORIZED PERSON.
- BURIAL DEPTH SPECIFICATIONS
 - ACCESSIBILITY
 - WHILE ALL TANKS ARE STRUCTURALLY DESIGNED FOR 2FT TO 6FT OF BURIAL DEPTH, IT IS NOT RECOMMENDED TO INSTALL TANKS DEEPER THAN 4FT AS THIS WILL LEAD TO MAINTENANCE AND ACCESSIBILITY ISSUES.
 - PLUMBING AND APPURTENANCES
 - ALL TANKS ARE DELIVERED WITH ENOUGH PLUMBING AND FIXTURES FOR A 4FT BURIAL DEPTH. CONTRACTOR WILL NEED TO PROVIDE ANY ADDITIONAL PLUMBING FOR TANKS BURIED DEEPER THAN 4FT
 - GREATER THAN 6FT BURIAL DEPTHER
 - PROJECTS REQUIRING GREATER THAN 6FT BURIAL DEPTH MUST BE CONSULTED WITH A PROFESSIONAL CIVIL OR GEOTECHNICAL ENGINEER BEFORE INSTALLATION.
- BACKFILL SPECIFICATIONS:
 - THE CONTRACTOR, ENGINEER, ARCHITECT, OR OWNER SHALL DETERMINE IF A TRAFFIC-RATED INSTALLATION IS REQUIRED. EXCAVATION SIZE AND BACKFILL SPECIFICATIONS WILL DIFFER WHEN TANK IS INSTALLED TO MEET TRAFFIC RATING REQUIREMENTS, AS DETAILED ON SUBSEQUENT DRAWINGS.
 - THE TANK MUST BE INSTALLED WITH SPECIFIED PRIMARY BACKFILL ONLY IN THE REGION IMMEDIATELY AROUND THE TANK. THE PRIMARY BACKFILL MUST EXTEND A MINIMUM OF 12 INCHES ON SIDES AND ENDS. PRIMARY BACKFILL UNDER THE TANK IS TO BE A MINIMUM OF 12 INCHES.
- SPECIFIED BACKFILL MATERIALS:
 - PEA GRAVEL:
 - NATURALLY ROUNDED AGGREGATE WITH A PARTIAL SIZE OF NOT LESS THAN 1/8 INCH AND NOT GREATER THAN 3/4 INCH. GRAVEL MUST BE CLEAN AND FREE FLOWING, AND FREE FROM DEBRIS.
 - CRUSHED STONE:
 - CRUSHED STONE OR GRAVEL WITH PARTIAL SIZE NOT LESS THAN 1/8 INCH AND NOT GREATER THAN 1/2 INCH. AGGREGATE MUST BE CLEAN AND FREE FLOWING, AND FREE FROM DEBRIS.
- SECONDARY BACKFILL SPECIFICATION:
 - SECONDARY BACKFILL CAN ONLY BE USED AT THE ABOVE-SPECIFIED DISTANCE FROM THE TANK WALLS. SECONDARY BACKFILL CAN BE USED AT MORE THAN 18 INCHES ABOVE TANK.
 - COURSE SAND OR GRAVEL:
 - COURSE SAND OR GRAVEL CONTAINING ROCKS NO LARGER THAN 1 1/2 INCHES.
 - BACKFILL SHALL BE CLEAN AND FREE FROM DEBRIS.
 - DURING PLACEMENT THIS BACKFILL MATERIAL MUST BE COMPACTED TO 95% RELATIVE COMPACTION. (AS MEASURED BY ASTM D1557 PROCEDURE.)
 - SELECT NATIVE BACKFILL:
 - SELECT NATIVE BACKFILL CONTAINING ROCKS NO LARGER THAN 1 1/2 INCHES. THIS MATERIAL CAN BE USED OUTSIDE OF ABOVE NOTED DISTANCES FROM THE TANK.
 - DURING PLACEMENT THIS BACKFILL MATERIAL MUST BE COMPACTED TO 95% RELATIVE COMPACTION. (AS MEASURED BY ASTM D1557 PROCEDURE.)
- ALL BACKFILL MATERIAL MUST BE FREE OF ICE AND SNOW AT TIME OF INSTALLATION, AND SHALL NOT CONTAIN LUMPS OR FROZEN MATERIAL AT ANY TIME DURING INSTALLATION.
- USE OF BACKFILL AND BEDDING MATERIAL OTHER THAN THAT SPECIFIED ABOVE WITHOUT PRIOR WRITTEN APPROVAL WILL VOID TANK WARRANTY.
- FILTER FABRIC LINER:
 - IT IS GEOLOGIST, GEOTECHNICAL ENGINEER OR OTHER QUALIFIED PROFESSIONAL RESPONSIBILITY TO DETERMINE IF A FILTER FABRIC LINER IS REQUIRED. THE FILTER FABRIC PREVENTS THE MIXING OF PEA GRAVEL WITH NATIVE SOIL AND KEEPS THE BACKFILL STABLE.
- BEDDING AND BACKFILL INSTRUCTIONS FOR WET HOLE INSTALLATION:
 - PREPARE EXCAVATION ACCORDING TO REQUIRED SIZE AND DEPTH. LEVEL BOTTOM OF HOLE. INSTALL APPROPRIATE PUMPING EQUIPMENT AT SIDE OF EXCAVATION LOWER THAN INTENDED BOTTOM OF EXCAVATION. MAINTAIN WATER LEVEL AS LOW AS POSSIBLE. LEVEL BOTTOM OF HOLE USING PRIMARY BACKFILL MATERIAL.
- PLACEMENT OF TANK ANCHORS:
 - PLACE TANK ANCHORS INTO EXCAVATION AT DESIRED DISTANCE APPROPRIATE FOR TANK DIAMETER. USE SETS OF CONCRETE DEADMEN DEPENDING ON THE LENGTH OF TANK. ALWAYS PROVIDE SUFFICIENT CLEARANCE TO ALLOW THE DEADMEN ANCHOR POINT TO BE SET OUTSIDE OF THE TANK "SHADOW". SEE STRUCTURAL DRAWINGS FOR DETAILS.

REINFORCED CONCRETE

- CEMENT TO BE TYPE V CONFORMING TO ASTM C-150.
- AGGREGATES SHALL CONFORM TO ASTM C-33 FOR STRUCTURAL NORMAL-WEIGHT CONCRETE (1" MAXIMUM SIZE) AND ASTM C-330 FOR STRUCTURAL LIGHTWEIGHT CONCRETE.
- READY-MIX CONCRETE SHALL BE MIXED AND DELIVERED IN ACCORDANCE WITH ASTM C-94.
- CONCRETE DESIGN MIXES SHALL BE IN ACCORDANCE WITH SECTION 1905 OF THE CALIFORNIA BUILDING CODE (CBC) OR APPROPRIATE LOCAL BUILDING CODES AND SHALL BE STAMPED AND SIGNED BY A REGISTERED PROFESSIONAL ENGINEER LICENSED IN THE STATE OF JURISDICTION.
- ALL CONCRETE SHALL SATISFY THE MINIMUM STRENGTH REQUIREMENTS. THE MINIMUM ULTIMATE COMPRESSIVE STRENGTH (F'C) AT 28 DAYS SHALL BE AS FOLLOWS:
 - 2500 PSI SLABS ON GRADE
 - 2500 PSI CONCRETE BEAMS *
 * USE 4=4500 PSI, W/J=0.45, TYPE V CEMENT WHERE SULFATE IS SEVERE, CORROSIVE SOIL OCCURS.
- SUBMIT HISTORICAL TEST DATA FOR ALL MIX DESIGNS. TEST DATA SHALL MEET THE REQUIREMENTS OF SEC. 1905.3 OF THE CBC OR APPROPRIATE LOCAL BUILDING CODES WHEN HISTORICAL DATA IS NOT AVAILABLE. THE REQUIRED CONCRETE COMPRESSIVE STRENGTH SHALL BE INCREASED IN ACCORDANCE WITH TABLE 19-A-7. THE CONCRETE SUPPLIER MUST BEAR THE TOTAL RESPONSIBILITY THAT THE MIX DESIGNS WILL ATTAIN THE REQUIRED STRENGTH AND SHRINKAGE CHARACTERISTICS. ACCEPTANCE OF MIX DESIGN WILL BE BASED ONLY ON CONFORMANCE OF SPECIFIED DESIGN STRENGTH AND DESIGN SLUMP.
- THE MINIMUM CEMENT CONTENT PER CUBIC YARD OF CONCRETE SHALL BE AS FOLLOWS:
 - 5 1/4 SACKS FOR 2000 PSI STRENGTH
 - 5 1/2 SACKS FOR 3500 PSI OR GREATER STRENGTH
 - WATER/CEMENT RATIO NOT TO EXCEED 0.45
- THE MAXIMUM CONCRETE SLUMP SHALL BE 3" +/- 1" FOR SLABS ON GRADE AND 4" +/- 1" FOR ALL OTHER WORK.
- THE USE OF FLY ASH SHALL BE CONSIDERED TO IMPROVE CONCRETE WORKABILITY AND DURABILITY ONLY. FLY ASH SHALL NOT BE CONSIDERED TO REDUCE THE MINIMUM CEMENT CONTENT. FLY ASH SHALL NOT BE USED IN POST-TENSIONED CONCRETE. FLY ASH SHALL CONFORM TO ASTM C-618, CLASS F. THE AMOUNT OF FLY ASH USED SHALL NOT EXCEED 15% OF THE CEMENT CONTENT.
- ADMIXTURES MAY BE USED WITH THE APPROVAL OF THE ENGINEER. ADMIXTURES USED TO INCREASE THE WORKABILITY OF THE CONCRETE SHALL NOT BE CONSIDERED TO REDUCE THE SPECIFIED MINIMUM CEMENT CONTENT. WHEN ADMIXTURES ARE UTILIZED, SUBMIT MANUFACTURER'S PRODUCT INFORMATION WITH THE CONCRETE MIX DESIGN. ADMIXTURES CONTAINING CALCIUM CHLORIDE SHALL NOT BE USED.
- AIR ENTRAINMENT OF 4% SHALL BE PROVIDED FOR SLABS ON GRADE. AIR-ENTRAINING ADMIXTURES SHALL CONFORM TO ATM C-260.
- PROJECTING CORNERS OF SLABS, BEAMS, WALLS, COLUMNS, ETC. SHALL BE FORMED WITH A 3/4" CHAMFER UNLESS OTHERWISE NOTED.
- CONCRETE FORM TOLERANCES SHALL BE WITHIN THE STANDARDS SET FORTH IN ACI 117.
- ALL REINFORCING STEEL, ANCHOR BOLTS, DOWELS AND OTHER INSERTS SHALL BE SECURED IN POSITION AND INSPECTED BY THE LOCAL BUILDING DEPARTMENT INSPECTOR PRIOR TO THE POURING OF ANY CONCRETE.
- THE LOCATION OF ALL CONSTRUCTION JOINTS, NOT SPECIFICALLY INDICATED ON THE DRAWINGS, SHALL BE APPROVED BY THE ENGINEER PRIOR TO PLACING REINFORCING STEEL.
- REFER TO AND VERIFY WITH ARCHITECTURAL DRAWINGS ANY MOULDS, GROOVES, REVEALS, SCUPPERS, ORNAMENTS, CLIPS OR TEXTURES REQUIRED TO BE CAST INTO CONCRETE AND FOR LOCATION AND EXTENT OF DEPRESSIONS, CURBS, AND RAMPS.
- WHEN POURING AN ANTI-FLOTATION COLLAR, THE SLAB CAN BE POURED TO ALLOW A TROUGH AROUND THE INLET AND OUTLET PIPES.
- PIPE MAY PASS THROUGH STRUCTURAL CONCRETE IN SLEEVES, BUT SHALL NOT BE EMBEDDED THEREIN. SLEEVES SHALL BE WRAPPED WITH EXPANSION JOINT FILLER MATERIAL TO ALLOW CONCRETE TO CURE WITHOUT RESTRAINT. PIPES OR CONDUITS EXCEEDING ONE-THIRD THE SLAB OR WALL THICKNESS SHALL NOT BE STRUCTURAL AND/OR ELECTRICAL DRAWINGS FOR LOCATION OF SLEEVES, ACCESSORIES, ETC.
- CONCRETE FLOOR SLABS VARIATION FROM LEVEL TO BE NOT MORE THAN 1/8" IN TEN FEET.
- DRY PACK: MIX, IN PROPORTIONS BY VOLUME, ONE PART CEMENT TO TWO-AND-ON-HALF PARTS FINE AGGREGATE. SCREENING OUT MATERIALS RETAINED ON NO. 4 SIEVE. MIX WITH WATER TO CONSISTENCY SUCH THAT, WHEN BALL OF MIXTURE IS COMPRESSED IN HAND, BALL WILL MAINTAIN SHAPE, SHOWING FINGER MARKS, BUT NOT SHOWING SURFACE WATER.

DIMENSIONS

- DIMENSIONS SHALL BE DEFINED TO INCLUDE BOTH HORIZONTAL DIMENSIONS AND VERTICAL DIMENSIONS (ELEVATIONS).
- WRITTEN DIMENSIONS SHALL SUPERCEDE SCALED DRAWINGS.
- SEE MANUFACTURE DRAWINGS FOR DIMENSIONS NOT NOTED ON STRUCTURAL DRAWINGS.

TIE DOWN

- GEOLOGIST OR GEOTECHNICAL ENGINEER OR OTHER QUALIFIED PROFESSIONAL SHALL DETERMINE IF TIE DOWNS ARE REQUIRED AND IF CORROSIVE PROTECTION MATERIALS (GALVANIZED, STAINLESS STEEL OR EPOXY COATING) ARE NEEDED.
- IF APPLICABLE, 2 STAINLESS STEEL (OR EQUIVALENT) STRAPS WILL BE USED, AS DETAILED ON SUBSEQUENT DRAWINGS.
- AS WITH ANY DEADMAN, WATER-TABLE HEIGHT AND BURIAL DEPTH MUST BE CONSIDERED IN SIZING THE DEADMAN SYSTEM.
- ALWAYS PROVIDE SUFFICIENT CLEARANCE TO ALLOW THE DEADMEN ANCHOR POINT TO BE SET OUTSIDE OF THE TANK "SHADOW".

REINFORCING STEEL

- BAR REINFORCEMENT SHALL CONFORM WITH ASTM A615, GRADE 60 UNO.
- ALL WELDED REBAR SHALL CONFORM WITH ASTM A706.
- WELDING OF REINFORCING STEEL SHALL CONFORM WITH AWS D1.4-92 OR LATEST EDITION.
- WELDED WIRE FABRIC SHALL CONFORM WITH ASTM A185 GRADE 65 FOR PLAIN WIRE AND ASTM A497 GRADE 80 FOR DEFORMED WIRE. ALL MESH SHALL HAVE A MINIMUM SIDE AND END LAP OF 1 1/2" MESH OR 9", WHICHEVER IS GREATER.
- REINFORCING DETAILING, BENDING AND PLACING SHALL BE IN ACCORDANCE WITH CONCRETE REINFORCING STEEL INSTITUTE "MANUAL OF STANDARD PRACTICE" LATEST EDITION.
- LAPS AT BAR SPLICES SHALL BE PER LAP SPLICE DETAILS.
- VERTICAL BARS IN WALLS SHALL BE ACCURATELY POSITIONED AT THE CENTER OF WALL. UNLESS OTHERWISE NOTED ON DETAILS, & SHALL BE TIED IN POSITION AT TOP AND BOTTOM AND AT INTERVALS NOT EXCEEDING 192 BAR DIA.
- BARS SHALL BE CLEAN OF MUD, OIL OR OTHER COATINGS LIKELY TO IMPAIR BONDING.
- REINFORCING BARS SHALL NOT BE RE-BENT WITHOUT APPROVAL OF STRUCTURAL ENGINEER. BENDS SHALL BE MADE COLD.
- UNLESS SHOWN OTHERWISE, REINFORCING BARS IN CONTINUOUS CONCRETE BEAMS AND SPANDRELS SHALL HAVE TOP BARS SPLICED AT THE MIDSPAN AND BOTTOM BARS SPLICED OVER THE SUPPORTS.
- REINFORCING STEEL SHALL BE PROVIDED WITH THE FLOWING AMOUNTS OF CONCRETE CLEAR COVER, UNLESS NOTED OTHERWISE:
 - FOOTINGS (CONCRETE DEPOSITED AGAINST EARTH).....3"
 - CONCRETE SURFACE (FORMED) EXPOSED TO EARTH OR WEATHER....2"
 - CONCRETE REINFORCING (INCLUDING COLUMN TIES).....1 1/2"
 - BEAMS AND GIRDERS.....1 1/2"
 - SLAB (#11 OR SMALLER).....3/4" BOTTOM
 - 1" TOP
- ALL REINFORCING STEEL, ANCHOR BOLTS, DOWELS, AND INSERTS SHALL BE WELL SECURED IN POSITION PRIOR TO PLACING CONCRETE OR GROUT.
- UNLESS OTHERWISE NOTED IN DETAILS, FURNISH #3 SPACER TIES AT APPROXIMATELY 2"-6" ON CENTER IN ALL BEAMS AND FOOTINGS TO SECURE REINFORCING IN PLACE.

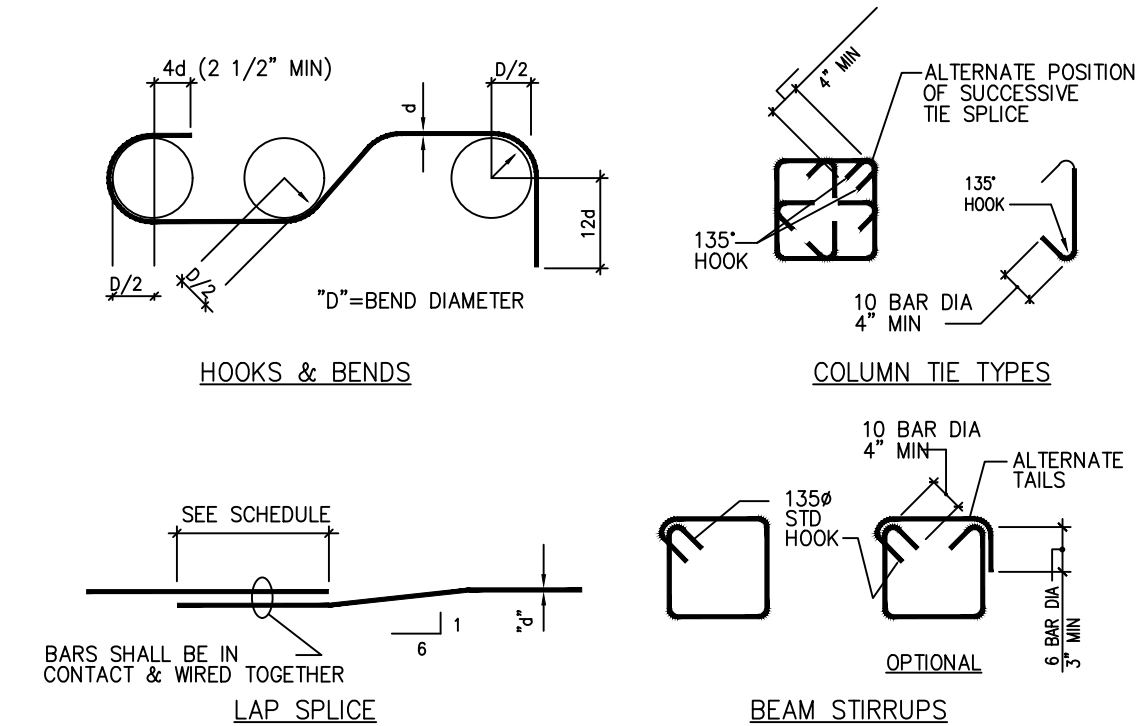

BEND DIAMETER SCHEDULE	
BAR SIZE	BEND DIAMETER
#3 THRU #5	D = 4d
#6 THRU #8	D = 6d
#9 THRU #11	D = 8d
#14 THRU #18	D = 10d

3000 PSI MIN. CONCRETE			CONCRETE BLOCK	
REINFORCING BAR LAP SPLICE				
BAR #	MINIMUM CLEAR BAR SPACING (BAR DIAMETER)	LAP SPLICE LENGTH (INCHES)		BAR LAP IN INCHES
		* TOP BARS	OTHER BARS	
#4	MORE THAN 2	30	23	24"
#5	MORE THAN 2	37	29	30"
#6	MORE THAN 2	44	34	54"
#7	MORE THAN 2	81	62	63"
#8	MORE THAN 2	93	72	72"
#9	MORE THAN 2	104	80	82"
#10	MORE THAN 2	116	89	92"
#11	MORE THAN 2	127	98	102"

* HORIZONTAL REINFORCEMENT SO PLACED THAT MORE THAN 12" OF FRESH CONCRETE IS CAST IN THE MEMBER BELOW THE DEVELOPMENT LENGTH OR SPLICE



31 AFFONSO DRIVE
MOUND HOUSE, NV 89706
1(877)-4SEPTIC [1(877)473-7842]
WWW.MICROSEPTEC.COM

NOTES

- GENERAL:
- THE MIDDLE THREE CHAMBERS SHOULD NEVER BE PUMPED DRY, ESPECIALLY IN HIGH GROUNDWATER CONDITIONS
 - RISERS AND RISER ADAPTERS NOT SUPPLIED BY MICROSEPTEC
 - PLUMBING DIMENSIONS FROM OUTSIDE EDGE OF TANK TO INVERT OF INLET AND OUTLET
 - CONTRACTOR TO PROVIDE ADDITIONAL PLUMBING FOR ANY BURIAL DEPTH GREATER THAN 4FT
 - SITE-SPECIFIC CHARACTERISTICS INCLUDING BUT NOT LIMITED TO: BURIAL DEPTH, TRAFFIC OR OTHER EXTERNAL LOADING, SEASONAL GROUNDWATER, AND SOIL CHARACTERISTICS SHOULD BE CONFIRMED WITH A LOCAL DESIGN ENGINEER BEFORE INSTALLATION
- TANK BURIAL:
- THE DESIGNED TANK BURIAL DEPTH IS 2FT TO 6FT. ANY TANK BURIED BEYOND THAT RANGE MUST BE ANALYZED BY A LOCAL DESIGN ENGINEER
 - COVER TO BE A MINIMUM OF 2FT.
 - ENGINEERED BACKFILL TO BE A MINIMUM OF 12" ALONG SIDES AND BOTTOM OF TANK
 - GEOLOGIST OR GEOTECHNICAL ENGINEER TO DETERMINE IF ANCHORS AND TEXTILE FILTER ARE REQUIRED
 - DEPTH OF SOIL SLOPE CUT PER LOCAL CODE OR SOIL REPORT
 - VERTICAL CUT FOR FILL HEIGHT CAN BE DONE IF APPROVED BY LOCAL CODE OR SOIL ENGINEER
 - GEOLOGIST OR GEOTECH ENGINEER SHOULD DETERMINE IF CORROSIVE RESISTANT MATERIAL SHOULD BE USED IN ANY STEEL PARTS EXPOSED IN THE SOIL. SEE SHEET IN25-01
- ANCHORING:
- ANCHORING AND ANTI-FLOATATION DESIGNS ARE NOT A ONE-SIZE-FITS-ALL DESIGN AND CONSIDER THE FOLLOWING CONDITIONS:
 - AT LEAST 2FT OF COVER
 - GROUNDWATER AT GRADE
 - MIDDLE THREE TANK CHAMBERS ARE 1/2 FULL OF WATER
 - TO DETERMINE THE EQUIVALENT FLUID WEIGHT OF EARTH OVER TOP OF THE TANK AND COUNTERWEIGHT, A GEOTECH ENGINEER OR OTHER PROFESSIONAL SHOULD BE CONSULTED
 - CONTROL JOINTS FOR ANCHORS ARE DETERMINED BY GENERAL CONTRACTOR

DRAWN:	DATE:	JOB NUMBER:
AJM	2/10/21	ES25 INSTALLATION

REVISION:		
REVISION:	DATE:	DESCRIPTION:

SITE INFORMATION:

ES 25
INSTALLATION DRAWING

SHEET TITLE:

GENERAL NOTES

SHEET NUMBER:

IN25-01

GENERAL NOTES

SCALE
NONE

1

ALARM CONTROL PANEL MCP-G & MCPR-G

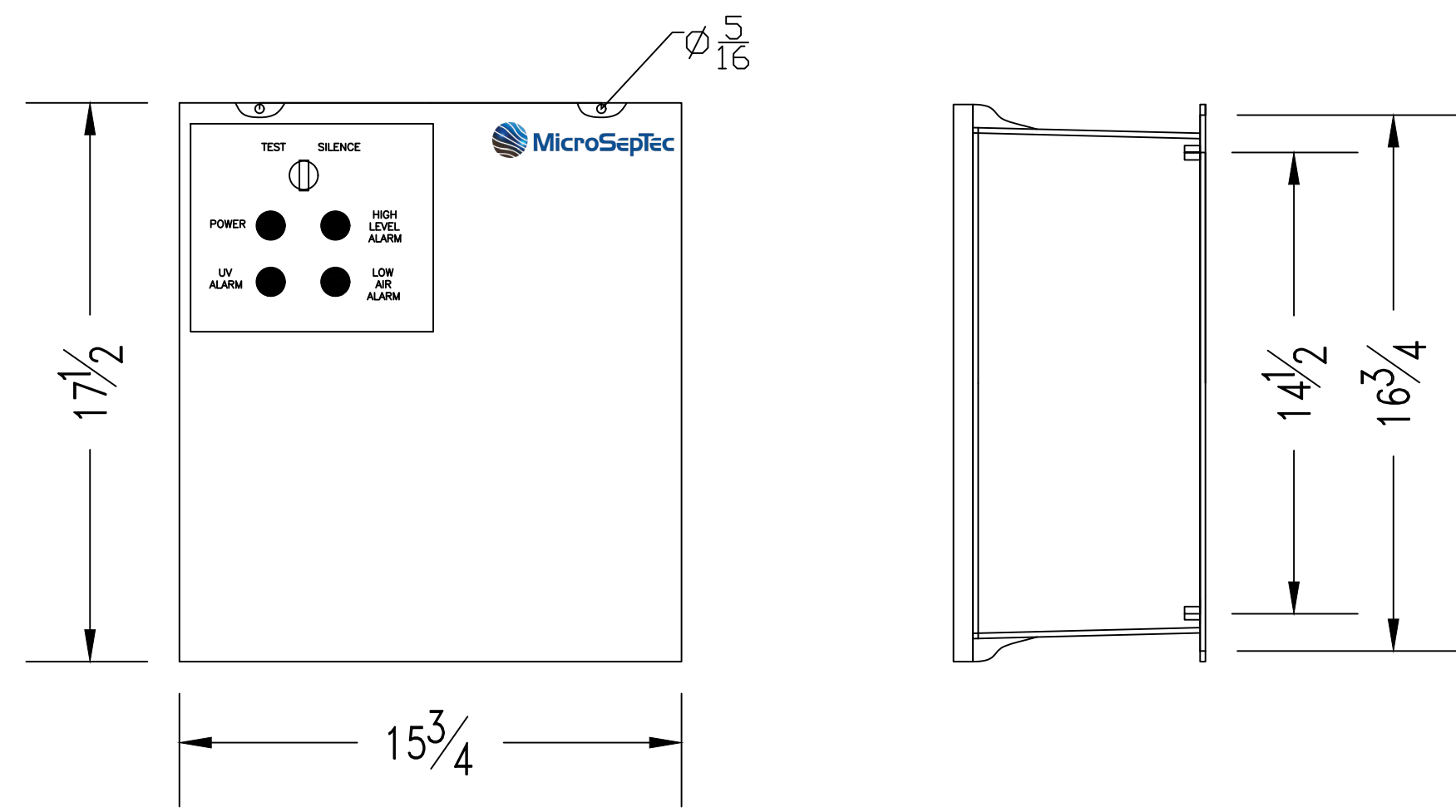

ALARM CONTROL PANEL MCPR-1DP & MCPR-2DP

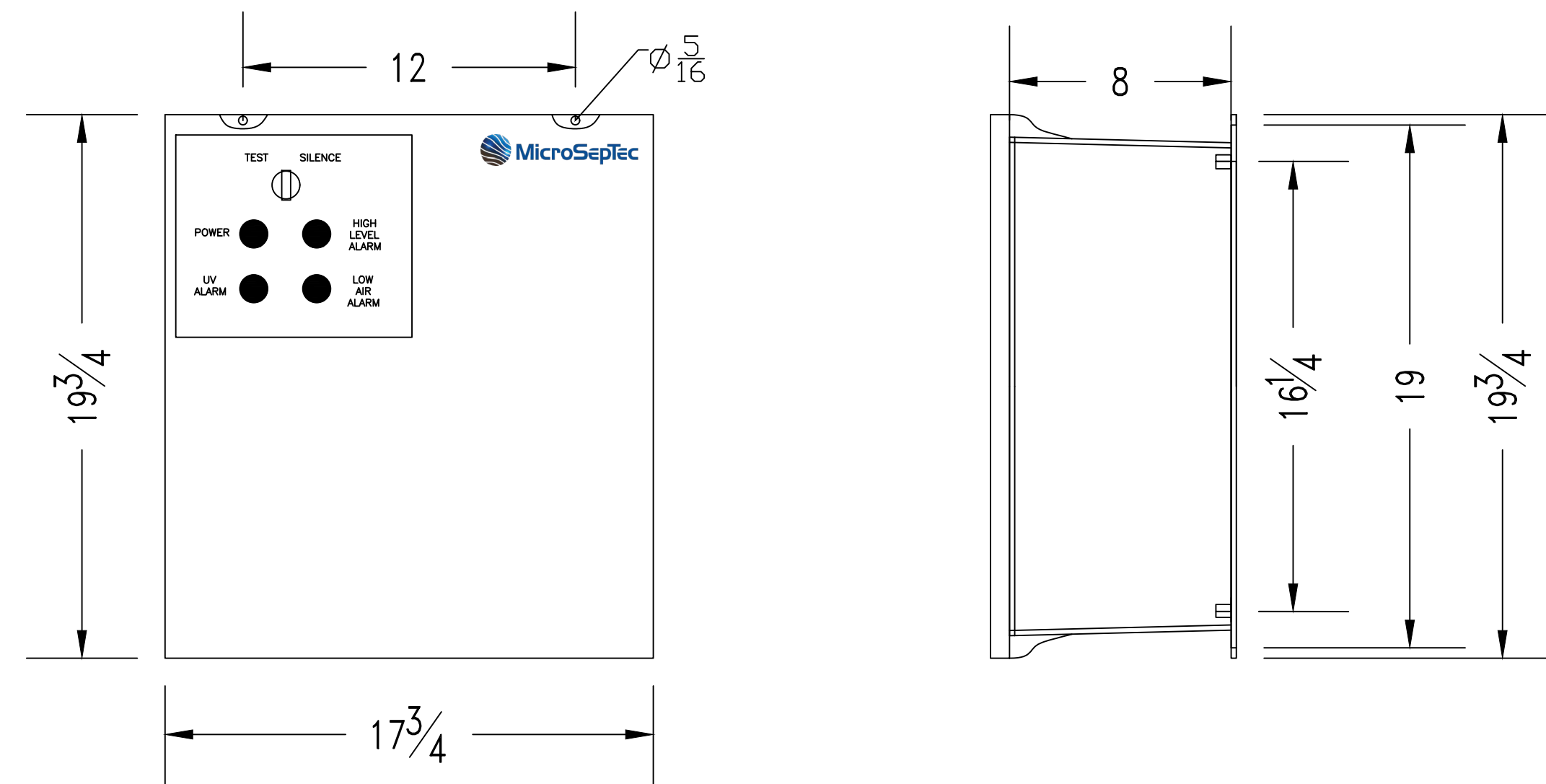

AIR COMPRESSOR

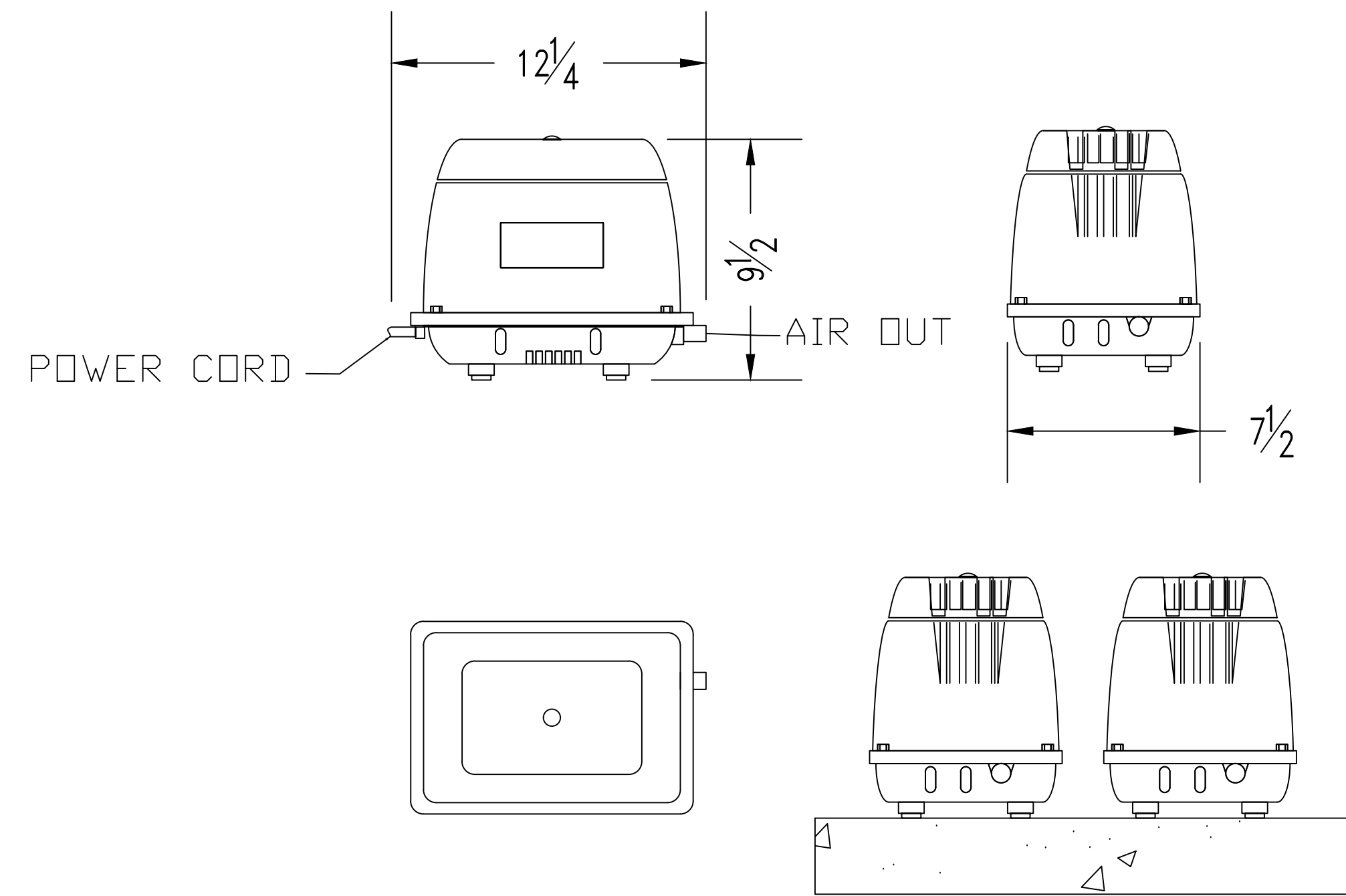

- COMPRESSORS SHOULD BE LOCATED IN A WELL-VENTILATED AND ACCESSIBLE SHADY PLACE. AN INDOOR LOCATION LIKE A SHED OR GARAGE IS IDEAL.
- ELEVATED OFF THE GROUND SO THAT SURFACE WATER CANNOT ENTER THE ELECTRICAL TERMINALS WITHIN THE COMPRESSOR.
- LOCATED AS CLOSE TO THE TANK AS POSSIBLE. DO NOT EXCEED 50' DISTANCE FROM TANK.
- PLUMBING FROM COMPRESSORS ENTER MIDDLE RISER
- PIPE FROM COMPRESSOR TO AIR SUPPLY INLET MUST FALL TOWARD TANK WITH NO LOW POINTS
- 1" SCH 80 PVC PIPE IS REQUIRED FOR PLUMBING THE COMPRESSOR(S) TO THE MIDDLE RISER; ONE PIPE PER COMPRESSOR.
- FOR COLD WEATHER INSTALLATION (WHERE AMBIENT AIR TEMPERATURE FALLS BELOW 32°F FOR EXTENDED PERIODS OF TIME) INSULATION OF THE AIRLINES FROM THE COMPRESSOR IS RECOMMENDED



31 AFFONSO DRIVE
MOUND HOUSE, NV 89706
1(877)-4SEPTIC [1(877)473-7842]
WWW.MICROSEPTEC.COM

NOTES

- GENERAL:
- THE MIDDLE THREE CHAMBERS SHOULD NEVER BE PUMPED DRY, ESPECIALLY IN HIGH GROUNDWATER CONDITIONS
 - RISERS AND RISER ADAPTERS NOT SUPPLIED BY MICROSEPTEC
 - PLUMBING DIMENSIONS FROM OUTSIDE EDGE OF TANK TO INVERT OF INLET AND OUTLET
 - CONTRACTOR TO PROVIDE ADDITIONAL PLUMBING FOR ANY BURIAL DEPTH GREATER THAN 4FT
 - SITE-SPECIFIC CHARACTERISTICS INCLUDING BUT NOT LIMITED TO: BURIAL DEPTH, TRAFFIC OR OTHER EXTERNAL LOADING, SEASONAL GROUNDWATER, AND SOIL CHARACTERISTICS SHOULD BE CONFIRMED WITH A LOCAL DESIGN ENGINEER BEFORE INSTALLATION
- TANK BURIAL:
- THE DESIGNED TANK BURIAL DEPTH IS 2FT TO 6FT. ANY TANK BURIED BEYOND THAT RANGE MUST BE ANALYZED BY A LOCAL DESIGN ENGINEER
 - COVER TO BE A MINIMUM OF 2FT.
 - ENGINEERED BACKFILL TO BE A MINIMUM OF 12" ALONG SIDES AND BOTTOM OF TANK
 - GEOLOGIST OR GEOTECHNICAL ENGINEER TO DETERMINE IF ANCHORS AND TEXTILE FILTER ARE REQUIRED.
 - DEPTH OF SOIL SLOPE CUT PER LOCAL CODE OR SOIL REPORT
 - VERTICAL CUT FOR FILL HEIGHT CAN BE DONE IF APPROVED BY LOCAL CODE OR SOIL ENGINEER
 - GEOLOGIST OR GEOTECH ENGINEER SHOULD DETERMINE IF CORROSIVE RESISTANT MATERIAL SHOULD BE USED IN ANY STEEL PARTS EXPOSED IN THE SOIL. SEE SHEET IN25-01
- ANCHORING:
- ANCHORING AND ANTI-FLOATATION DESIGNS ARE NOT A ONE-SIZE-FITS-ALL DESIGN AND CONSIDER THE FOLLOWING CONDITIONS:
 - AT LEAST 2FT OF COVER
 - GROUNDWATER AT GRADE
 - MIDDLE THREE TANK CHAMBERS ARE 1/2 FULL OF WATER
 - TO DETERMINE THE EQUIVALENT FLUID WEIGHT OF EARTH OVER TOP OF THE TANK AND COUNTERWEIGHT, A GEOTECH ENGINEER OR OTHER PROFESSIONAL SHOULD BE CONSULTED
 - CONTROL JOINTS FOR ANCHORS ARE DETERMINED BY GENERAL CONTRACTOR

DRAWN:	DATE:	JOB NUMBER:
AJM	2/10/21	ES25 INSTALLATION

REVISION:		
REVISION:	DATE:	DESCRIPTION:

SITE INFORMATION:

ES 25
INSTALLATION DRAWING

SHEET TITLE:

ALARM CONTROL PANEL
AND AIR COMPRESSOR DETAIL

SHEET NUMBER:

IN25-02

NOTES

- GENERAL:
1. THE MIDDLE THREE CHAMBERS SHOULD NEVER BE PUMPED DRY, ESPECIALLY IN HIGH GROUNDWATER CONDITIONS
 2. RISERS AND RISER ADAPTERS NOT SUPPLIED BY MICROSEPTEC
 3. PLUMBING DIMENSIONS FROM OUTSIDE EDGE OF TANK TO INVERT OF INLET AND OUTLET
 4. CONTRACTOR TO PROVIDE ADDITIONAL PLUMBING FOR ANY BURIAL DEPTH GREATER THAN 4FT
 5. SITE-SPECIFIC CHARACTERISTICS INCLUDING BUT NOT LIMITED TO: BURIAL DEPTH, TRAFFIC OR OTHER EXTERNAL LOADING, SEASONAL GROUNDWATER, AND SOIL CHARACTERISTICS SHOULD BE CONFIRMED WITH A LOCAL DESIGN ENGINEER BEFORE INSTALLATION

- TANK BURIAL:
6. THE DESIGNED TANK BURIAL DEPTH IS 2FT TO 6FT. ANY TANK BURIED BEYOND THAT RANGE MUST BE ANALYZED BY A LOCAL DESIGN ENGINEER
 7. COVER TO BE A MINIMUM OF 2FT.
 8. ENGINEERED BACKFILL TO BE A MINIMUM OF 12" ALONG SIDES AND BOTTOM OF TANK
 9. GEOLOGIST OR GEOTECHNICAL ENGINEER TO DETERMINE IF ANCHORS AND TEXTILE FILTER ARE REQUIRED
 10. DEPTH OF SOIL SLOPE CUT PER LOCAL CODE OR SOIL REPORT
 11. VERTICAL CUT FOR FILL HEIGHT CAN BE DONE IF APPROVED BY LOCAL CODE OR SOIL ENGINEER
 12. GEOLOGIST OR GEOTECH ENGINEER SHOULD DETERMINE IF CORROSIVE RESISTANT MATERIAL SHOULD BE USED IN ANY STEEL PARTS EXPOSED IN THE SOIL. SEE SHEET IN25-01

- ANCHORING:
13. ANCHORING AND ANTI-FLOATATION DESIGNS ARE NOT A ONE-SIZE-FITS-ALL DESIGN AND CONSIDER THE FOLLOWING CONDITIONS:
 - 13.1. AT LEAST 2FT OF COVER
 - 13.2. GROUNDWATER AT GRADE
 - 13.3. MIDDLE THREE TANK CHAMBERS ARE 1/2 FULL OF WATER
 14. TO DETERMINE THE EQUIVALENT FLUID WEIGHT OF EARTH OVER TOP OF THE TANK AND COUNTERWEIGHT, A GEOTECH ENGINEER OR OTHER PROFESSIONAL SHOULD BE CONSULTED
 15. CONTROL JOINTS FOR ANCHORS ARE DETERMINED BY GENERAL CONTRACTOR

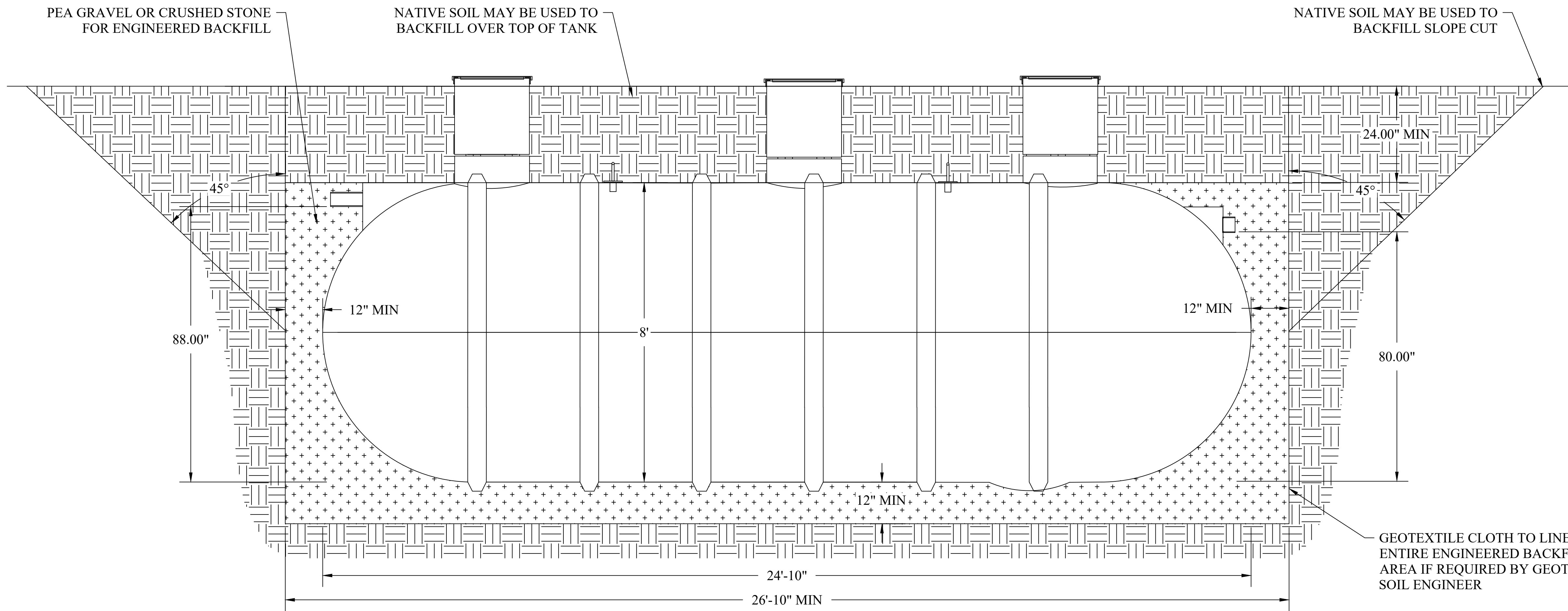

TANK INSTALLATION LAYOUT (ELEVATION VIEW)

SCALE NONE 1

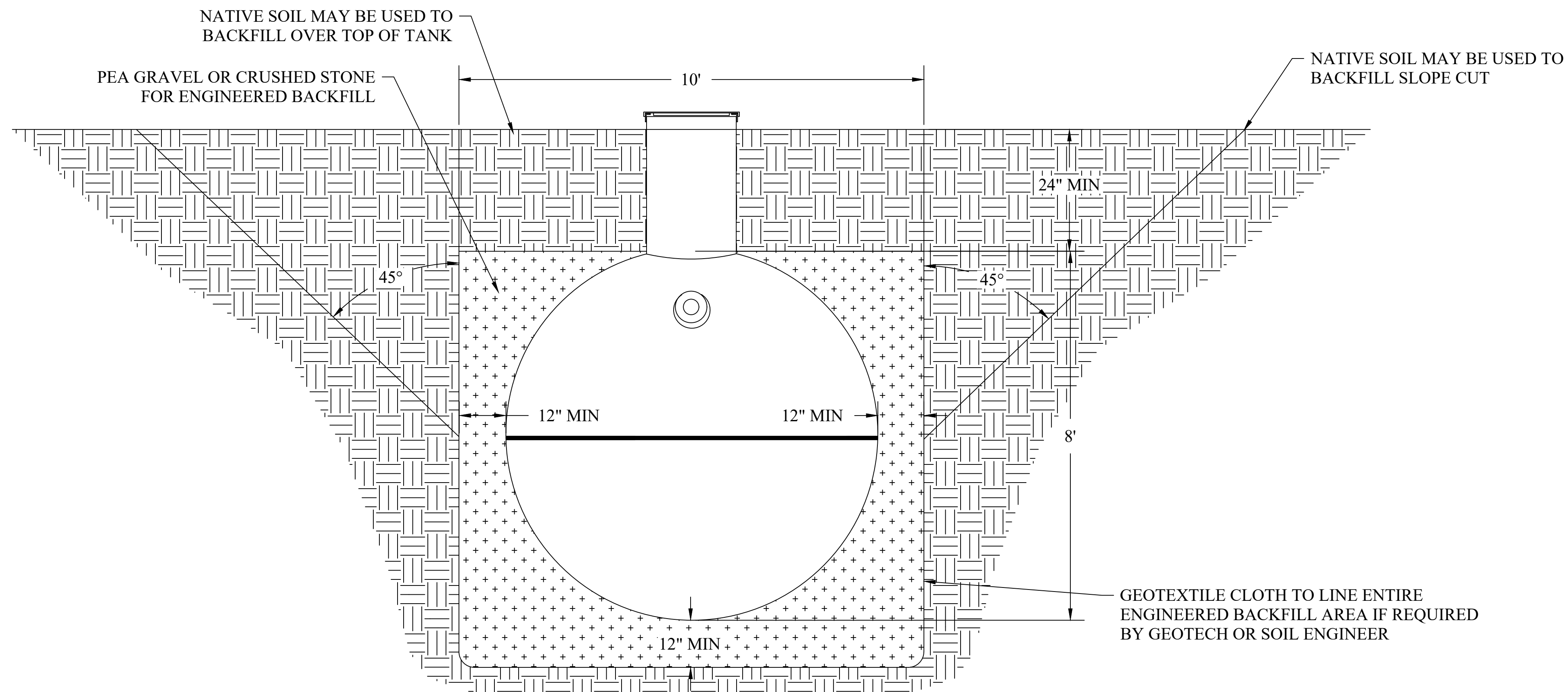

TANK INLET VIEW

SCALE NONE 2

DRAWN:	DATE:	JOB NUMBER:
AJM	2/10/21	ES25 INSTALLATION

REVISION:		
REVISION:	DATE BY:	DESCRIPTION:

SITE INFORMATION:

ES 25
 INSTALLATION DRAWING

SHEET TITLE:

NON-TRAFFIC
 INSTALLATION (TYPICAL)

SHEET NUMBER:

IN25-03

NOTES

- GENERAL:
1. THE MIDDLE THREE CHAMBERS SHOULD NEVER BE PUMPED DRY, ESPECIALLY IN HIGH GROUNDWATER CONDITIONS
 2. RISERS AND RISER ADAPTERS NOT SUPPLIED BY MICROSEPTEC
 3. PLUMBING DIMENSIONS FROM OUTSIDE EDGE OF TANK TO INVERT OF INLET AND OUTLET
 4. CONTRACTOR TO PROVIDE ADDITIONAL PLUMBING FOR ANY BURIAL DEPTH GREATER THAN 4FT
 5. SITE-SPECIFIC CHARACTERISTICS INCLUDING BUT NOT LIMITED TO: BURIAL DEPTH, TRAFFIC OR OTHER EXTERNAL LOADING, SEASONAL GROUNDWATER, AND SOIL CHARACTERISTICS SHOULD BE CONFIRMED WITH A LOCAL DESIGN ENGINEER BEFORE INSTALLATION
- TANK BURIAL:
6. THE DESIGNED TANK BURIAL DEPTH IS 2FT TO 6FT. ANY TANK BURIED BEYOND THAT RANGE MUST BE ANALYZED BY A LOCAL DESIGN ENGINEER
 7. COVER TO BE A MINIMUM OF 2FT.
 8. ENGINEERED BACKFILL TO BE A MINIMUM OF 12" ALONG SIDES AND BOTTOM OF TANK
 9. GEOLOGIST OR GEOTECHNICAL ENGINEER TO DETERMINE IF ANCHORS AND TEXTILE FILTER ARE REQUIRED
 10. DEPTH OF SOIL SLOPE CUT PER LOCAL CODE OR SOIL REPORT
 11. VERTICAL CUT FOR FILL HEIGHT CAN BE DONE IF APPROVED BY LOCAL CODE OR SOIL ENGINEER
 12. GEOLOGIST OR GEOTECH ENGINEER SHOULD DETERMINE IF CORROSIVE RESISTANT MATERIAL SHOULD BE USED IN ANY STEEL PARTS EXPOSED IN THE SOIL. SEE SHEET IN25-01
- ANCHORING:
13. ANCHORING AND ANTI-FLOATATION DESIGNS ARE NOT A ONE-SIZE-FITS-ALL DESIGN AND CONSIDER THE FOLLOWING CONDITIONS:
 - 13.1. AT LEAST 2FT OF COVER
 - 13.2. GROUNDWATER AT GRADE
 - 13.3. MIDDLE THREE TANK CHAMBERS ARE 1/2 FULL OF WATER
 14. TO DETERMINE THE EQUIVALENT FLUID WEIGHT OF EARTH OVER TOP OF THE TANK AND COUNTERWEIGHT, A GEOTECH ENGINEER OR OTHER PROFESSIONAL SHOULD BE CONSULTED
 15. CONTROL JOINTS FOR ANCHORS ARE DETERMINED BY GENERAL CONTRACTOR

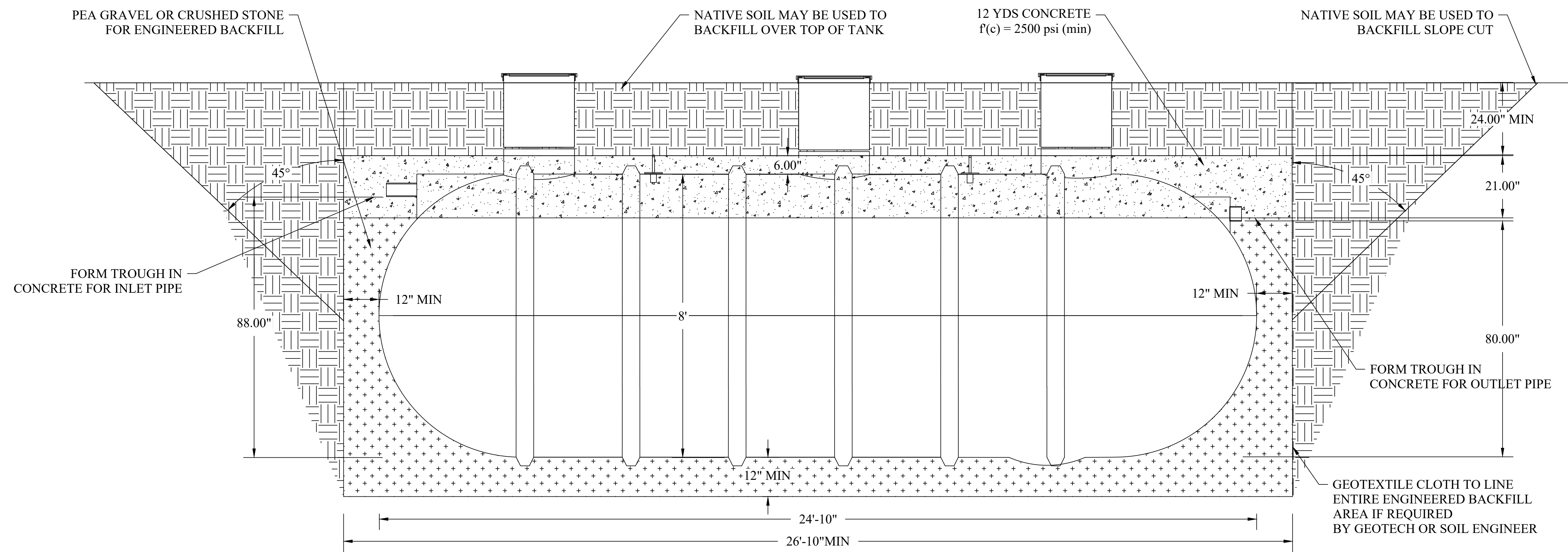

TANK INSTALLATION LAYOUT (ELEVATION VIEW)

SCALE NONE 1

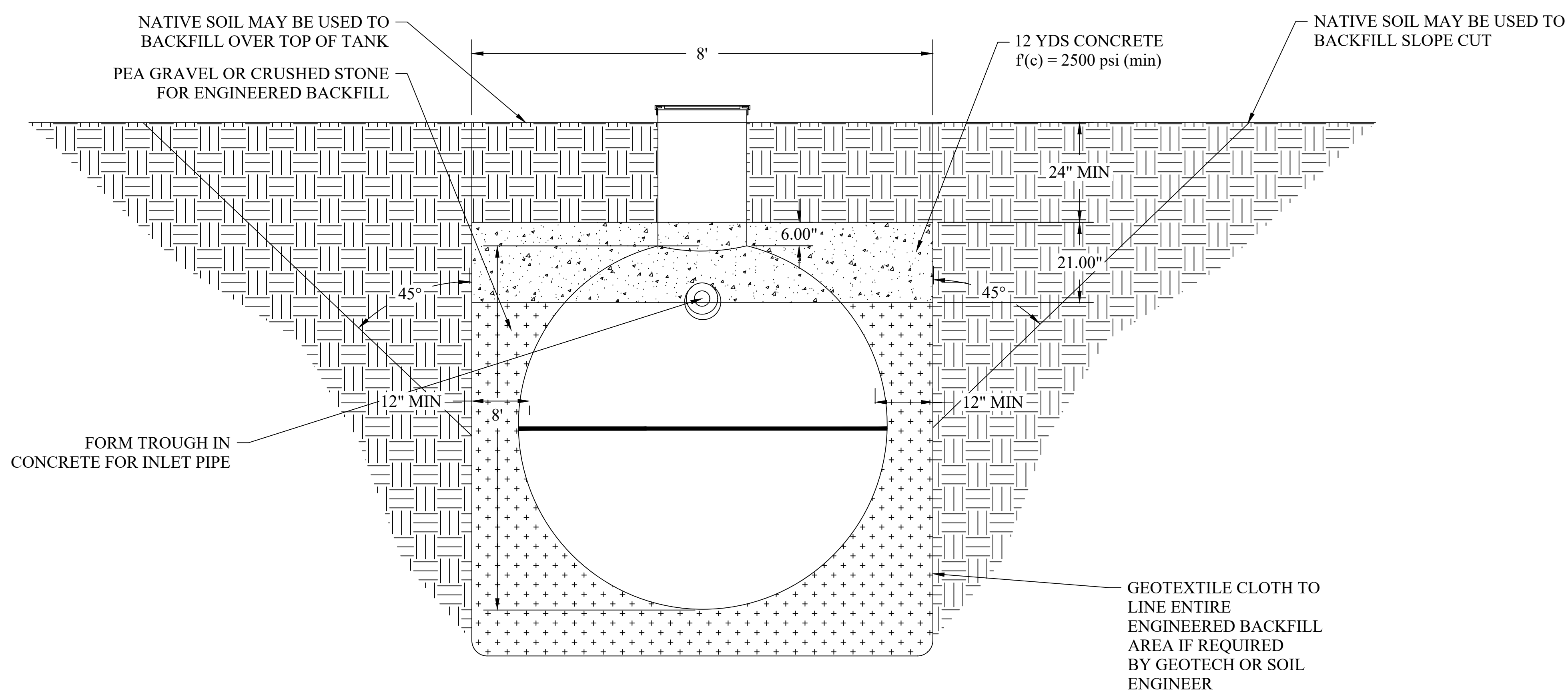

TANK INLET VIEW

SCALE NONE 2

DRAWN:	DATE:	JOB NUMBER:
AJM	2/10/21	ES25 INSTALLATION

REVISION:		
REVISION:	DATE:	DESCRIPTION:

SITE INFORMATION:

ES 25
 INSTALLATION DRAWING

SHEET TITLE:

NON-TRAFFIC INSTALLATION
 WITH ANTI-FLOATATION
 COLLAR

SHEET NUMBER:

IN25-05

NOTES

- GENERAL:
- THE MIDDLE THREE CHAMBERS SHOULD NEVER BE PUMPED DRY, ESPECIALLY IN HIGH GROUNDWATER CONDITIONS
 - RISERS AND RISER ADAPTERS NOT SUPPLIED BY MICROSEPTEC
 - PLUMBING DIMENSIONS FROM OUTSIDE EDGE OF TANK TO INVERT OF INLET AND OUTLET
 - CONTRACTOR TO PROVIDE ADDITIONAL PLUMBING FOR ANY BURIAL DEPTH GREATER THAN 4FT
 - SITE-SPECIFIC CHARACTERISTICS INCLUDING BUT NOT LIMITED TO: BURIAL DEPTH, TRAFFIC OR OTHER EXTERNAL LOADING, SEASONAL GROUNDWATER, AND SOIL CHARACTERISTICS SHOULD BE CONFIRMED WITH A LOCAL DESIGN ENGINEER BEFORE INSTALLATION
- TANK BURIAL:
- THE DESIGNED TANK BURIAL DEPTH IS 2FT TO 6FT. ANY TANK BURIED BEYOND THAT RANGE MUST BE ANALYZED BY A LOCAL DESIGN ENGINEER
 - COVER TO BE A MINIMUM OF 2FT.
 - ENGINEERED BACKFILL TO BE A MINIMUM OF 12" ALONG SIDES AND BOTTOM OF TANK
 - GEOLOGIST OR GEOTECHNICAL ENGINEER TO DETERMINE IF ANCHORS AND TEXTILE FILTER ARE REQUIRED.
 - DEPTH OF SOIL SLOPE CUT PER LOCAL CODE OR SOIL REPORT
 - VERTICAL CUT FOR FILL HEIGHT CAN BE DONE IF APPROVED BY LOCAL CODE OR SOIL ENGINEER
 - GEOLOGIST OR GEOTECH ENGINEER SHOULD DETERMINE IF CORROSIVE RESISTANT MATERIAL SHOULD BE USED IN ANY STEEL PARTS EXPOSED IN THE SOIL. SEE SHEET IN25-01
- ANCHORING:
- ANCHORING AND ANTI-FLOATATION DESIGNS ARE NOT A ONE-SIZE-FITS-ALL DESIGN AND CONSIDER THE FOLLOWING CONDITIONS:
 - AT LEAST 2FT OF COVER
 - GROUNDWATER AT GRADE
 - MIDDLE THREE TANK CHAMBERS ARE 1/2 FULL OF WATER
 - TO DETERMINE THE EQUIVALENT FLUID WEIGHT OF EARTH OVER TOP OF THE TANK AND COUNTERWEIGHT, A GEOTECH ENGINEER OR OTHER PROFESSIONAL SHOULD BE CONSULTED
 - CONTROL JOINTS FOR ANCHORS ARE DETERMINED BY GENERAL CONTRACTOR

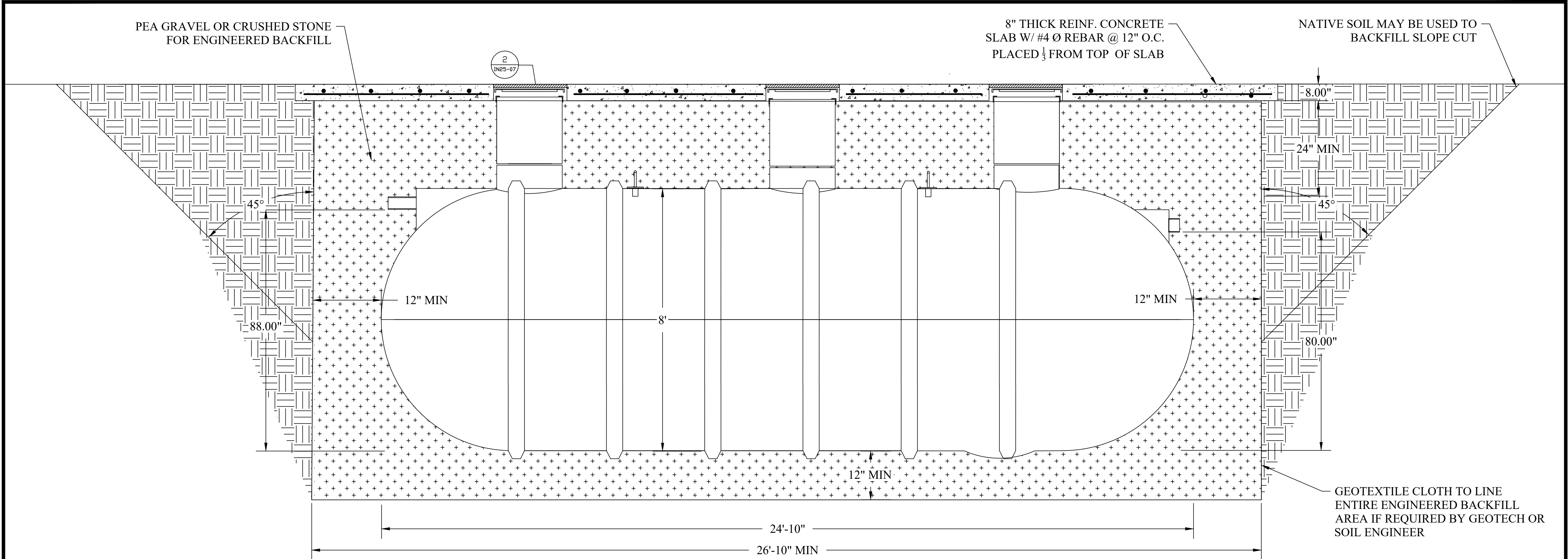

TANK INSTALLATION LAYOUT (ELEVATION VIEW) SCALE NONE 1

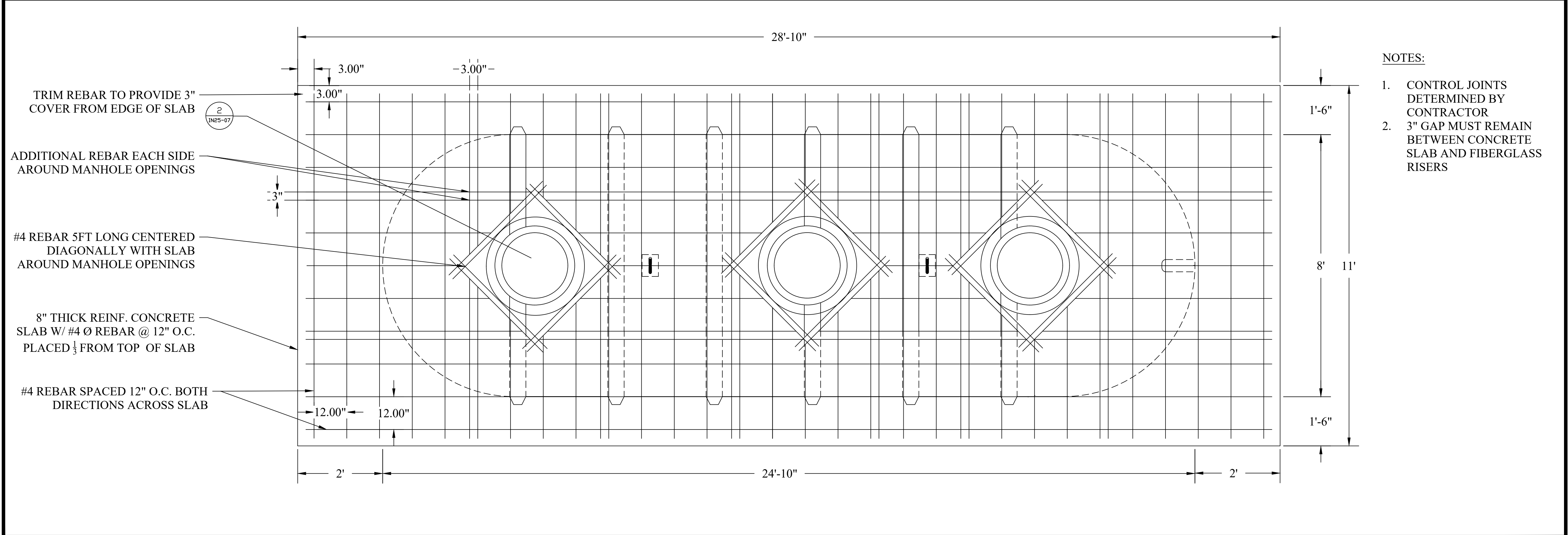

TANK INSTALLATION LAYOUT (PLAN VIEW) SCALE NONE 2

DRAWN:	DATE:	JOB NUMBER:
AJM	2/10/21	ES25 INSTALLATION

REVISION:		
REVISION:	DATE:	DESCRIPTION:

SITE INFORMATION:

ES 25
 INSTALLATION DRAWING

SHEET TITLE:

H2O TRAFFIC SLAB
 INSTALLATION

SHEET NUMBER:

IN25-06

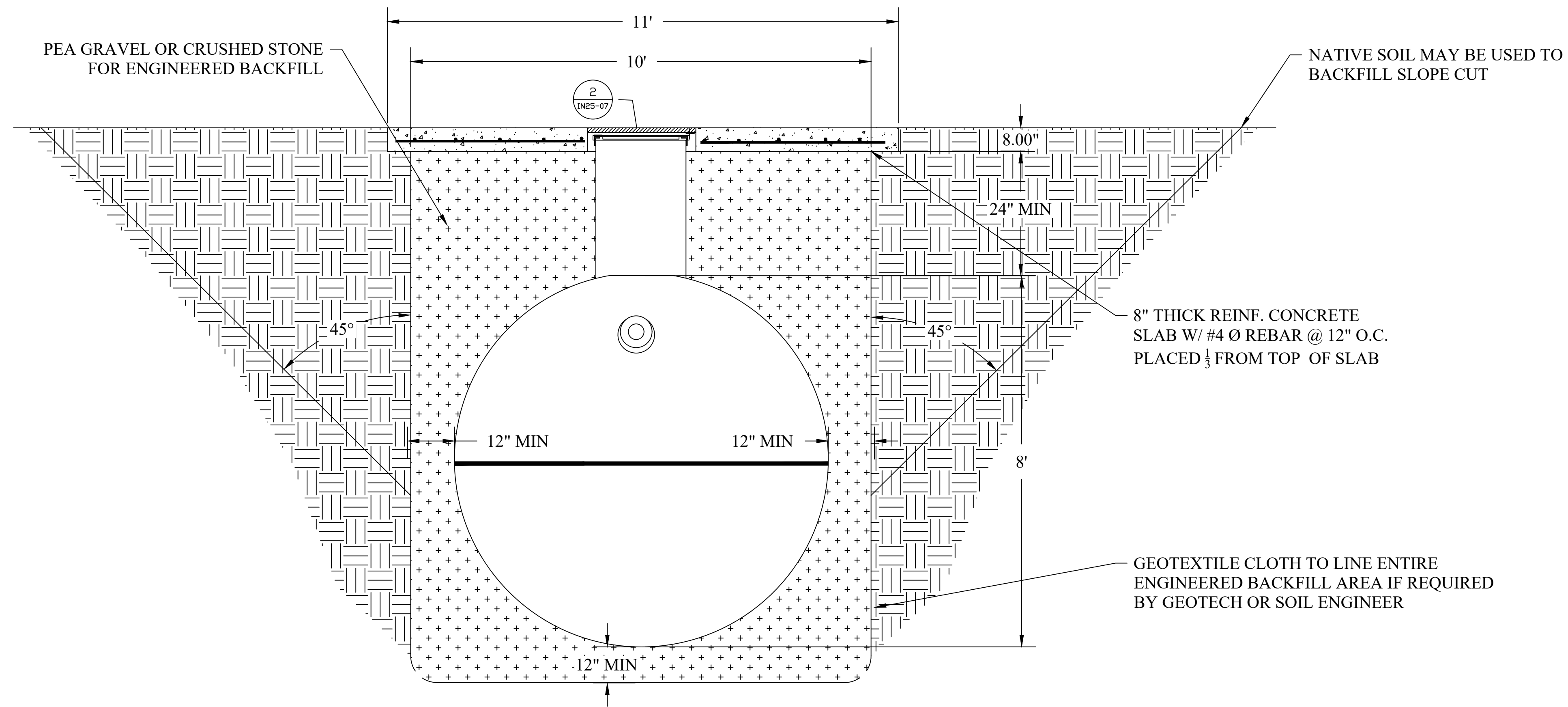

NOTES

- GENERAL:**
1. THE MIDDLE THREE CHAMBERS SHOULD NEVER BE PUMPED DRY, ESPECIALLY IN HIGH GROUNDWATER CONDITIONS
 2. RISERS AND RISER ADAPTERS NOT SUPPLIED BY MICROSEPTEC
 3. PLUMBING DIMENSIONS FROM OUTSIDE EDGE OF TANK TO INVERT OF INLET AND OUTLET
 4. CONTRACTOR TO PROVIDE ADDITIONAL PLUMBING FOR ANY BURIAL DEPTH GREATER THAN 4FT
 5. SITE-SPECIFIC CHARACTERISTICS INCLUDING BUT NOT LIMITED TO: BURIAL DEPTH, TRAFFIC OR OTHER EXTERNAL LOADING, SEASONAL GROUNDWATER, AND SOIL CHARACTERISTICS SHOULD BE CONFIRMED WITH A LOCAL DESIGN ENGINEER BEFORE INSTALLATION
- TANK BURIAL:**
6. THE DESIGNED TANK BURIAL DEPTH IS 2FT TO 6FT. ANY TANK BURIED BEYOND THAT RANGE MUST BE ANALYZED BY A LOCAL DESIGN ENGINEER
 7. COVER TO BE A MINIMUM OF 2FT.
 8. ENGINEERED BACKFILL TO BE A MINIMUM OF 12" ALONG SIDES AND BOTTOM OF TANK
 9. GEOLOGIST OR GEOTECHNICAL ENGINEER TO DETERMINE IF ANCHORS AND TEXTILE FILTER ARE REQUIRED
 10. DEPTH OF SOIL SLOPE CUT PER LOCAL CODE OR SOIL REPORT
 11. VERTICAL CUT FOR FILL HEIGHT CAN BE DONE IF APPROVED BY LOCAL CODE OR SOIL ENGINEER
 12. GEOLOGIST OR GEOTECH ENGINEER SHOULD DETERMINE IF CORROSIVE RESISTANT MATERIAL SHOULD BE USED IN ANY STEEL PARTS EXPOSED IN THE SOIL. SEE SHEET IN25-01
- ANCHORING:**
13. ANCHORING AND ANTI-FLOATATION DESIGNS ARE NOT A ONE-SIZE-FITS-ALL DESIGN AND CONSIDER THE FOLLOWING CONDITIONS:
 - 13.1. AT LEAST 2FT OF COVER
 - 13.2. GROUNDWATER AT GRADE
 - 13.3. MIDDLE THREE TANK CHAMBERS ARE 1/2 FULL OF WATER
 14. TO DETERMINE THE EQUIVALENT FLUID WEIGHT OF EARTH OVER TOP OF THE TANK AND COUNTERWEIGHT, A GEOTECH ENGINEER OR OTHER PROFESSIONAL SHOULD BE CONSULTED
 15. CONTROL JOINTS FOR ANCHORS ARE DETERMINED BY GENERAL CONTRACTOR

TANK INLET VIEW

SCALE NONE 1

30" WATER-TIGHT MANHOLE. CAST IRON COVER AND FRAME. H-20-RATED ALHAMBRA FOUNDRY OR EQUAL. A-1252B (TRAFFIC) A-1262B (NON TRAFFIC)

NOTE: IF CONCRETE RINGS ARE USED, THEY MUST NOT COME INTO CONTACT WITH TANK, MUST BE A MINIMUM OF 18" ABOVE THE TOP OF THE TANK, AND MUST BE TIED TO SLAB WITH REBAR.

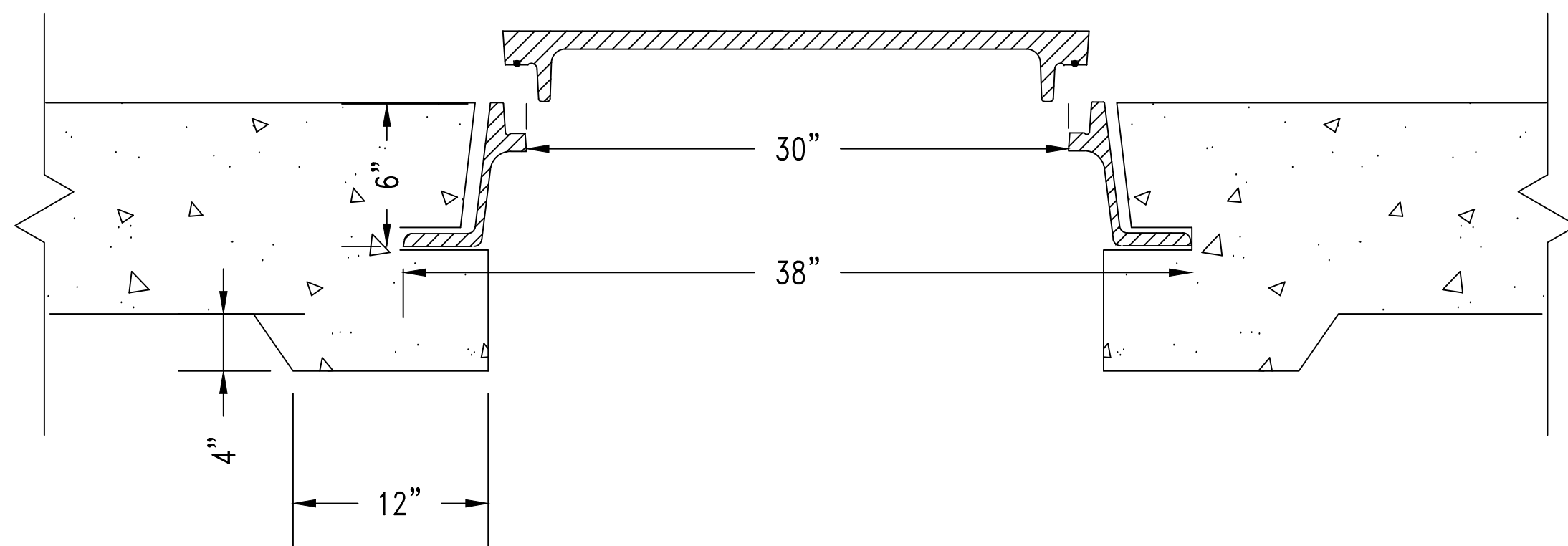

MANHOLE DETAIL FOR 24" RISER

SCALE NONE 2

36" WATER-TIGHT MANHOLE. CAST IRON COVER AND FRAME. H-20-RATED ALHAMBRA FOUNDRY OR EQUAL. A-1251B (TRAFFIC & NON TRAFFIC)

NOTE: IF CONCRETE RINGS ARE USED, THEY MUST NOT COME INTO CONTACT WITH TANK, MUST BE A MINIMUM OF 18" ABOVE THE TOP OF THE TANK, AND MUST BE TIED TO SLAB WITH REBAR.

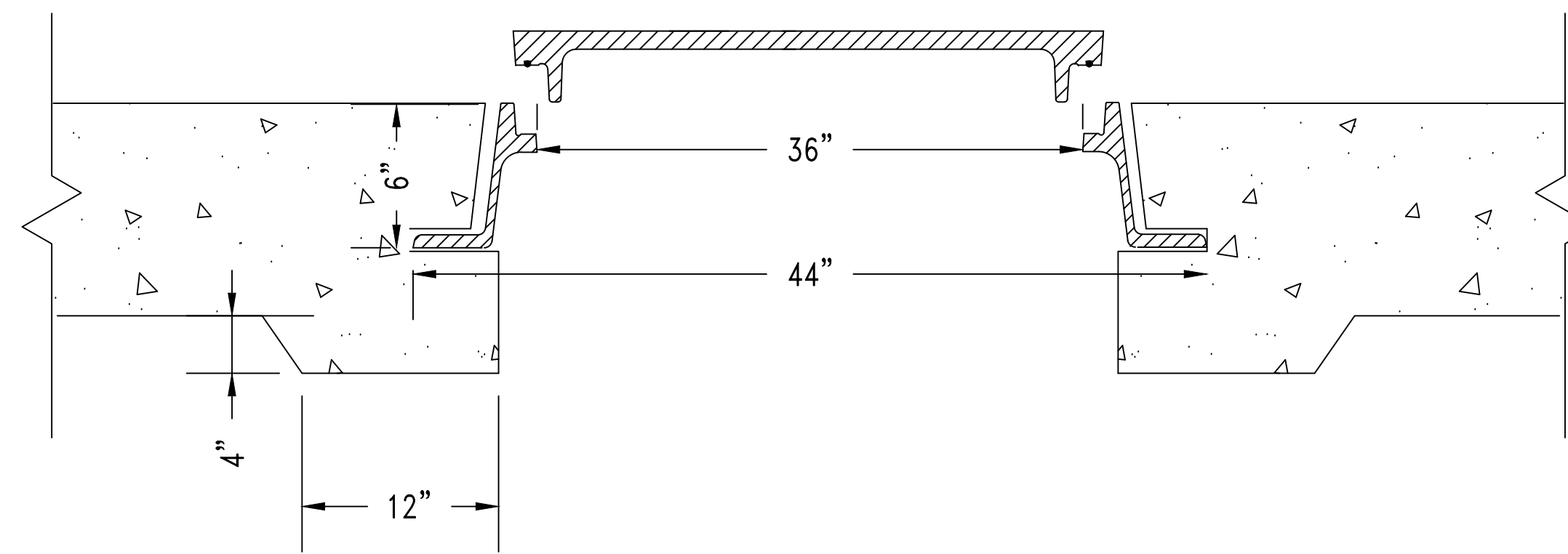

MANHOLE DETAIL FOR 30" RISER

SCALE NONE 3

DRAWN:	DATE:	JOB NUMBER:
AJM	2/10/21	ES25 INSTALLATION

REVISION:		
REVISION:	DATE:	DESCRIPTION:

SITE INFORMATION:
 ES 25
 INSTALLATION DRAWING

SHEET TITLE:
 H2O TRAFFIC SLAB
 INSTALLATION

SHEET NUMBER:
 IN25-07

NOTES

- GENERAL:
1. THE MIDDLE THREE CHAMBERS SHOULD NEVER BE PUMPED DRY, ESPECIALLY IN HIGH GROUNDWATER CONDITIONS
 2. RISERS AND RISER ADAPTERS NOT SUPPLIED BY MICROSEPTEC
 3. PLUMBING DIMENSIONS FROM OUTSIDE EDGE OF TANK TO INVERT OF INLET AND OUTLET
 4. CONTRACTOR TO PROVIDE ADDITIONAL PLUMBING FOR ANY BURIAL DEPTH GREATER THAN 4FT
 5. SITE-SPECIFIC CHARACTERISTICS INCLUDING BUT NOT LIMITED TO: BURIAL DEPTH, TRAFFIC OR OTHER EXTERNAL LOADING, SEASONAL GROUNDWATER, AND SOIL CHARACTERISTICS SHOULD BE CONFIRMED WITH A LOCAL DESIGN ENGINEER BEFORE INSTALLATION

- TANK BURIAL:
6. THE DESIGNED TANK BURIAL DEPTH IS 2FT TO 6FT. ANY TANK BURIED BEYOND THAT RANGE MUST BE ANALYZED BY A LOCAL DESIGN ENGINEER
 7. COVER TO BE A MINIMUM OF 2FT.
 8. ENGINEERED BACKFILL TO BE A MINIMUM OF 12" ALONG SIDES AND BOTTOM OF TANK
 9. GEOLOGIST OR GEOTECHNICAL ENGINEER TO DETERMINE IF ANCHORS AND TEXTILE FILTER ARE REQUIRED
 10. DEPTH OF SOIL SLOPE CUT PER LOCAL CODE OR SOIL REPORT
 11. VERTICAL CUT FOR FILL HEIGHT CAN BE DONE IF APPROVED BY LOCAL CODE OR SOIL ENGINEER
 12. GEOLOGIST OR GEOTECH ENGINEER SHOULD DETERMINE IF CORROSIVE RESISTANT MATERIAL SHOULD BE USED IN ANY STEEL PARTS EXPOSED IN THE SOIL. SEE SHEET IN25-01

- ANCHORING:
13. ANCHORING AND ANTI-FLOATATION DESIGNS ARE NOT A ONE-SIZE-FITS-ALL DESIGN AND CONSIDER THE FOLLOWING CONDITIONS:
 - 13.1. AT LEAST 2FT OF COVER
 - 13.2. GROUNDWATER AT GRADE
 - 13.3. MIDDLE THREE TANK CHAMBERS ARE 1/2 FULL OF WATER
 14. TO DETERMINE THE EQUIVALENT FLUID WEIGHT OF EARTH OVER TOP OF THE TANK AND COUNTERWEIGHT, A GEOTECH ENGINEER OR OTHER PROFESSIONAL SHOULD BE CONSULTED
 15. CONTROL JOINTS FOR ANCHORS ARE DETERMINED BY GENERAL CONTRACTOR

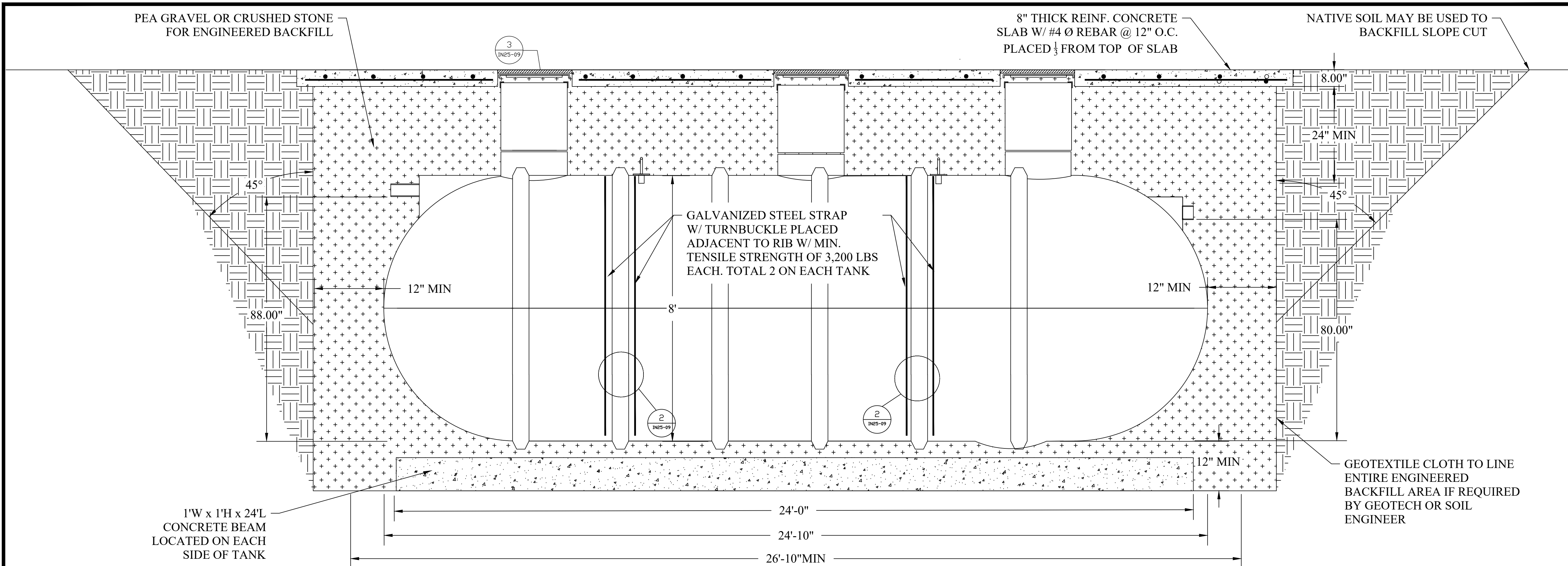

TANK INSTALLATION LAYOUT (ELEVATION VIEW)

SCALE NONE 1

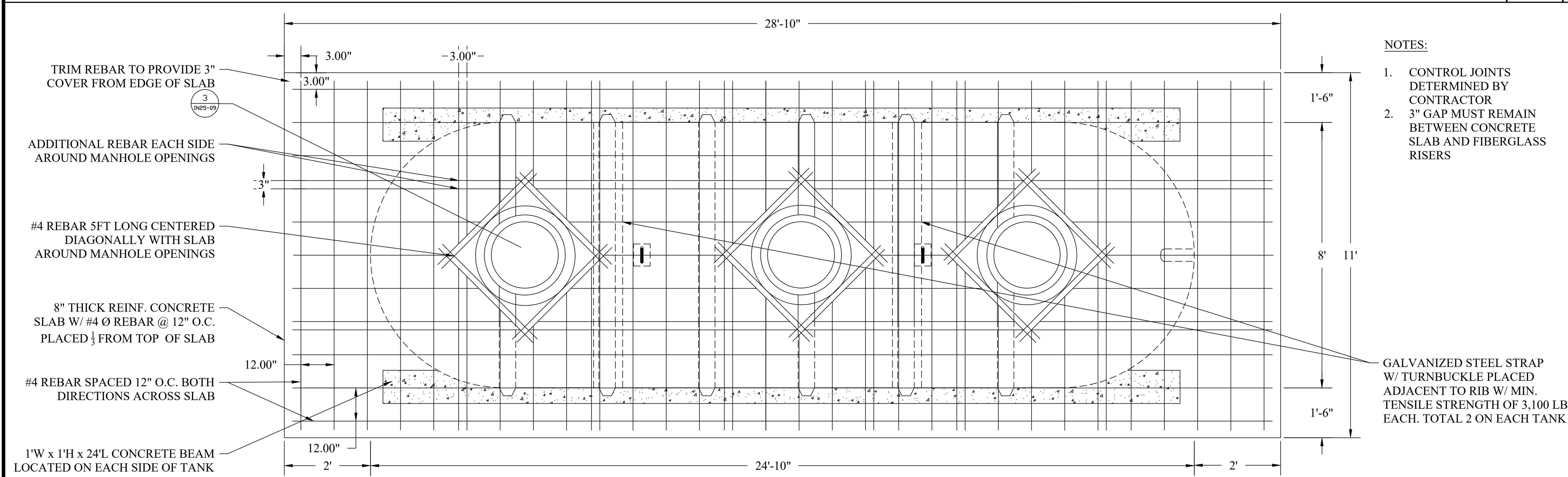

TANK INSTALLATION LAYOUT (PLAN VIEW)

SCALE NONE 2

DRAWN:	DATE:	JOB NUMBER:
AJM	2/10/21	ES25 INSTALLATION

REVISION:		
REVISION:	DATE:	DESCRIPTION:

SITE INFORMATION:

ES 25
 INSTALLATION DRAWING

SHEET TITLE:

H2O TRAFFIC SLAB WITH
 ANTI-FLOATATION ANCHORS

SHEET NUMBER:

IN25-08

NOTES

- GENERAL:
- THE MIDDLE THREE CHAMBERS SHOULD NEVER BE PUMPED DRY, ESPECIALLY IN HIGH GROUNDWATER CONDITIONS
 - RISERS AND RISER ADAPTERS NOT SUPPLIED BY MICROSEPTEC
 - PLUMBING DIMENSIONS FROM OUTSIDE EDGE OF TANK TO INVERT OF INLET AND OUTLET
 - CONTRACTOR TO PROVIDE ADDITIONAL PLUMBING FOR ANY BURIAL DEPTH GREATER THAN 4FT
 - SITE-SPECIFIC CHARACTERISTICS INCLUDING BUT NOT LIMITED TO: BURIAL DEPTH, TRAFFIC OR OTHER EXTERNAL LOADING, SEASONAL GROUNDWATER, AND SOIL CHARACTERISTICS SHOULD BE CONFIRMED WITH A LOCAL DESIGN ENGINEER BEFORE INSTALLATION
- TANK BURIAL:
- THE DESIGNED TANK BURIAL DEPTH IS 2FT TO 6FT. ANY TANK BURIED BEYOND THAT RANGE MUST BE ANALYZED BY A LOCAL DESIGN ENGINEER
 - ENGINEERED BACKFILL TO BE A MINIMUM OF 12" COVER TO BE A MINIMUM OF 2FT.
 - GEOLOGIST OR GEOTECHNICAL ENGINEER TO DETERMINE IF ANCHORS AND TEXTILE FILTER ARE REQUIRED.
 - DEPTH OF SOIL SLOPE CUT PER LOCAL CODE OR SOIL REPORT
 - VERTICAL CUT FOR FILL HEIGHT CAN BE DONE IF APPROVED BY LOCAL CODE OR SOIL ENGINEER
 - GEOLOGIST OR GEOTECH ENGINEER SHOULD DETERMINE IF CORROSIVE RESISTANT MATERIAL SHOULD BE USED IN ANY STEEL PARTS EXPOSED IN THE SOIL. SEE SHEET IN25-01
- ANCHORING:
- ANCHORING AND ANTI-FLOATATION DESIGNS ARE NOT A ONE-SIZE-FITS-ALL DESIGN AND CONSIDER THE FOLLOWING CONDITIONS:
 - AT LEAST 2FT OF COVER
 - GROUNDWATER AT GRADE
 - MIDDLE THREE TANK CHAMBERS ARE $\frac{2}{3}$ FULL OF WATER
 - TO DETERMINE THE EQUIVALENT FLUID WEIGHT OF EARTH OVER TOP OF THE TANK AND COUNTERWEIGHT, A GEOTECH ENGINEER OR OTHER PROFESSIONAL SHOULD BE CONSULTED
 - CONTROL JOINTS FOR ANCHORS ARE DETERMINED BY GENERAL CONTRACTOR

TIE DOWN AND ANCHOR BEAM ARE DESIGNED BASED ON THE MIDDLE THREE COMPARTMENTS OF THE TANK BEING $\frac{3}{4}$ FULL OF WATER WITH GROUNDWATER AT GRADE

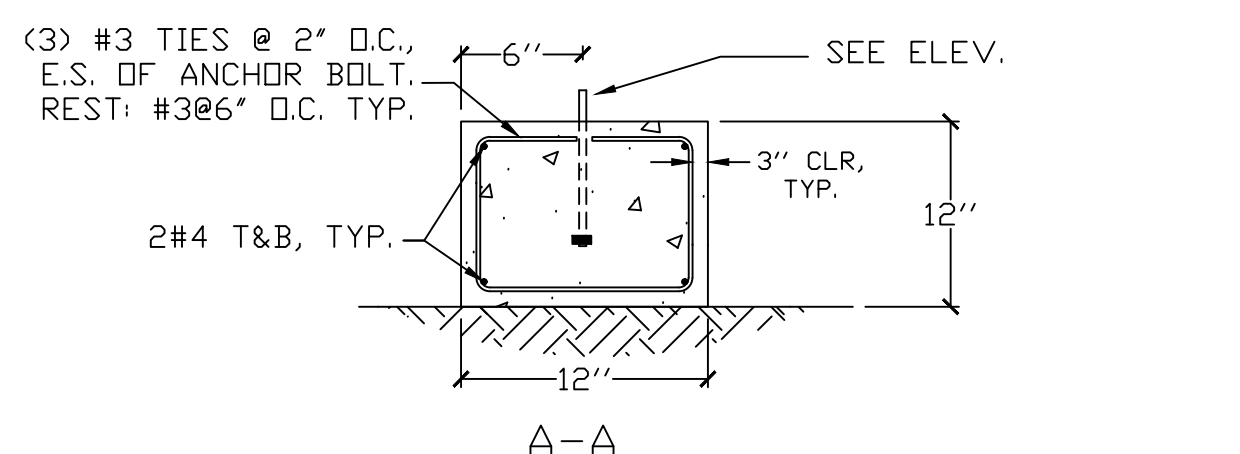
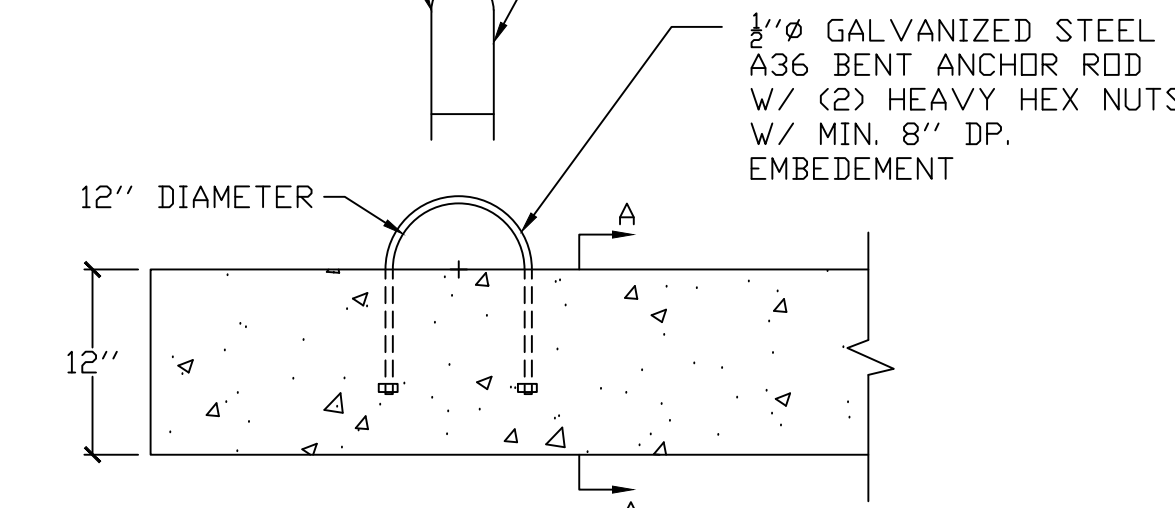
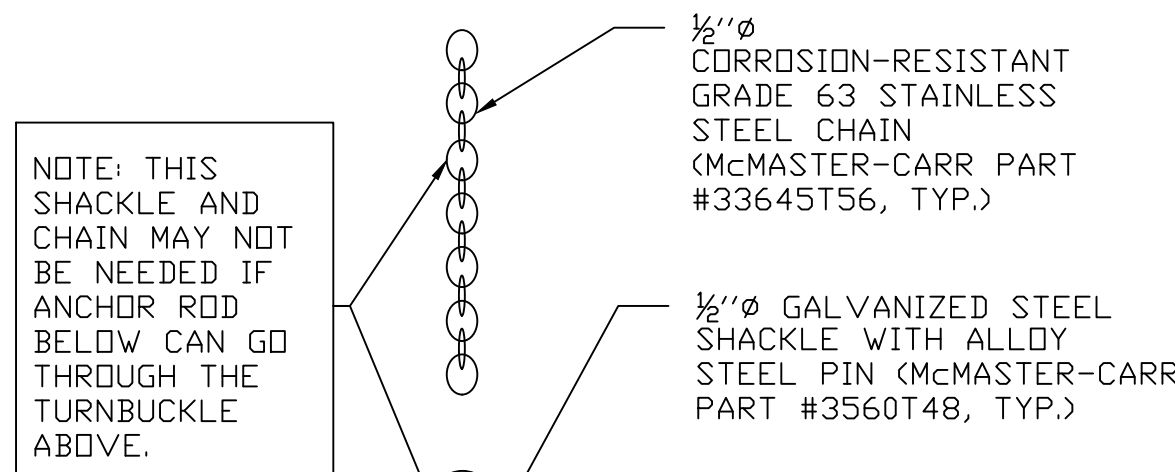
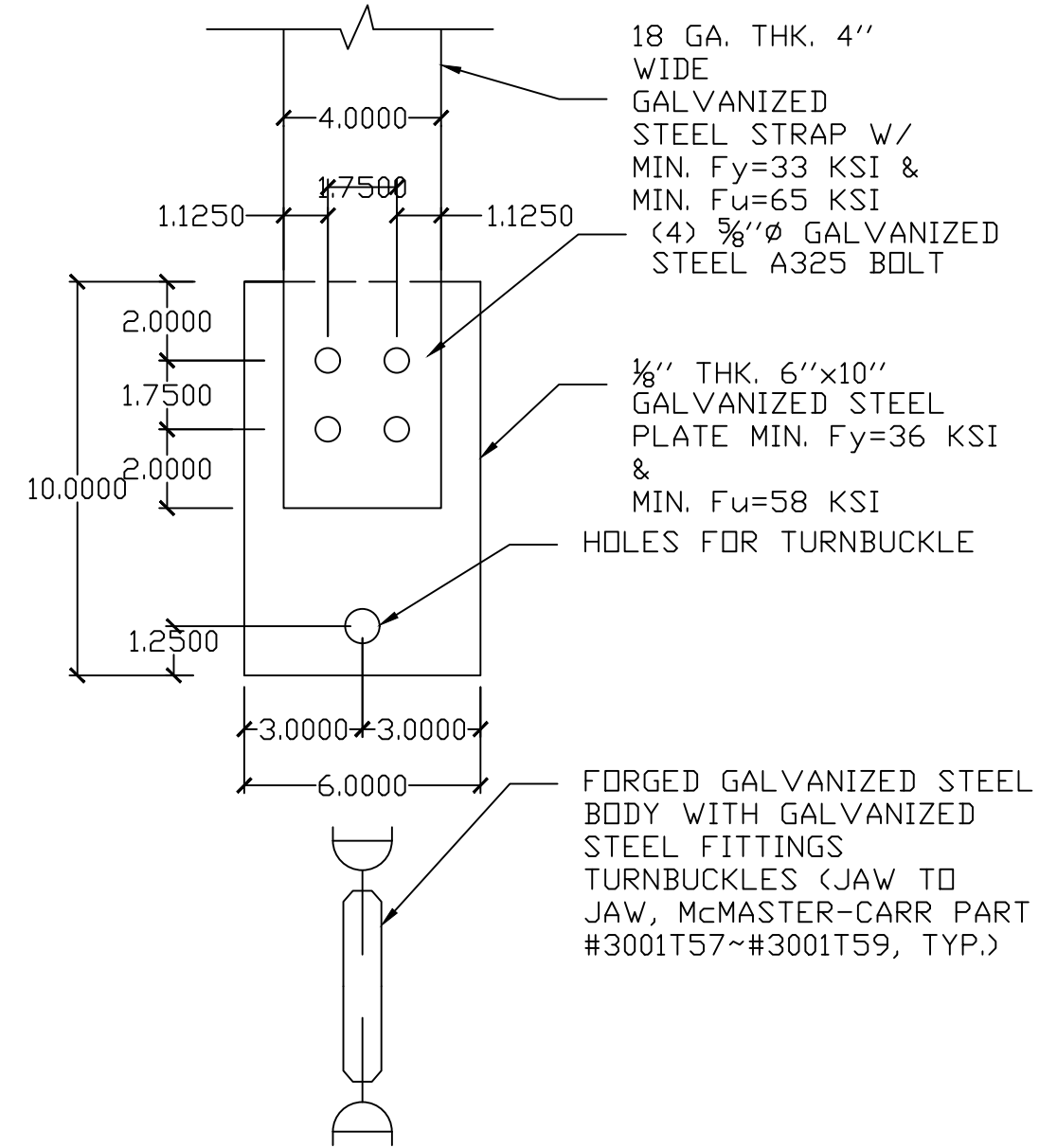

NOTE: ABOVE HARDWARE IS NOT INTENDED TO USE IN CORROSIVE SOIL. GEOLOGIST OR GEOGRAPHICAL ENGINEER SHOULD DETERMINE IF CORROSIVE RESISTANT MATERIAL (SUCH AS STAINLESS STEEL, OR SPECIAL COATING) SHOULD BE USED IN ANY STEEL PARTS EXPOSED IN THE SOIL. SEE SHEET IN25-01.

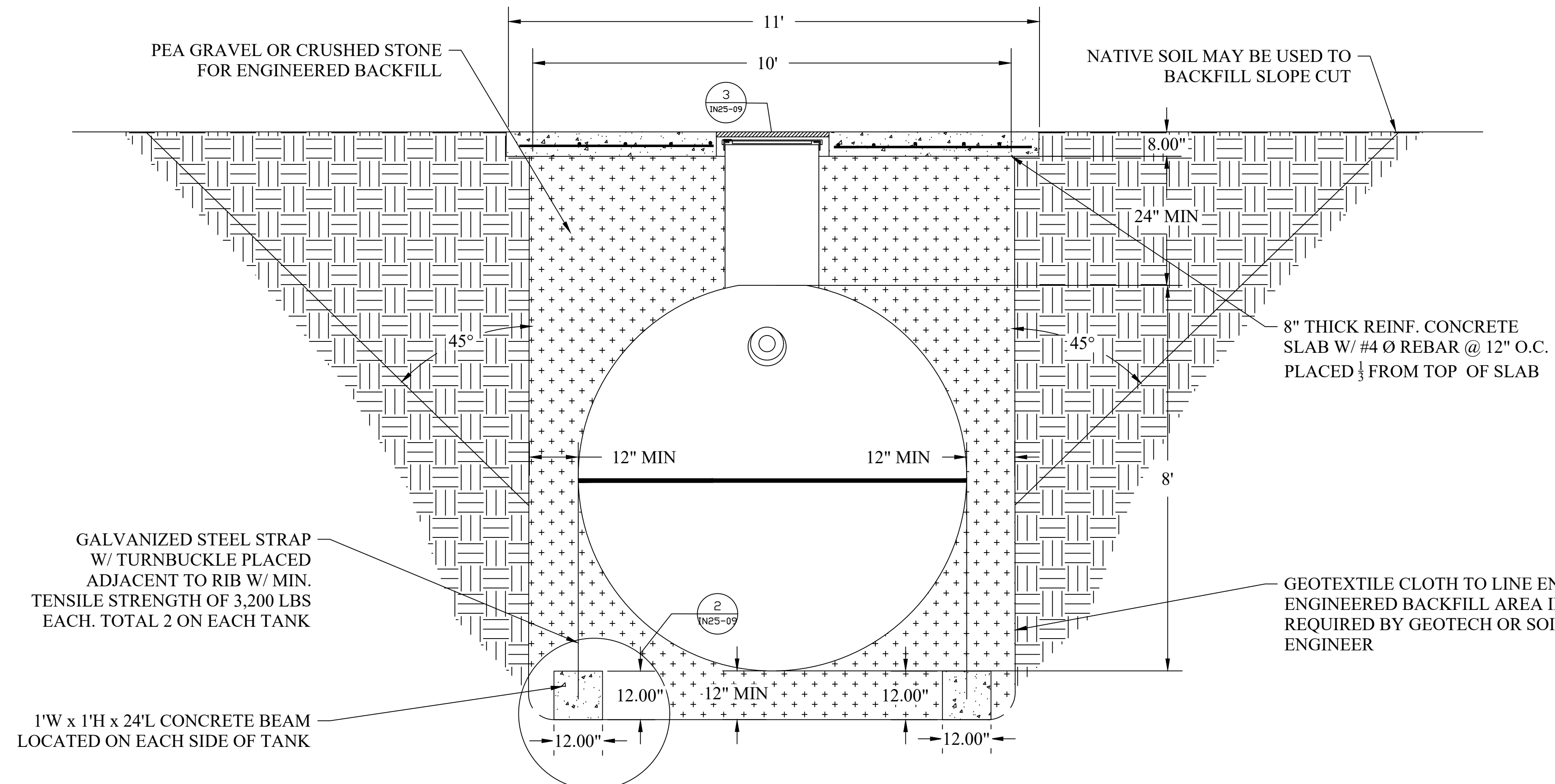

TANK INLET VIEW

SCALE NONE 1

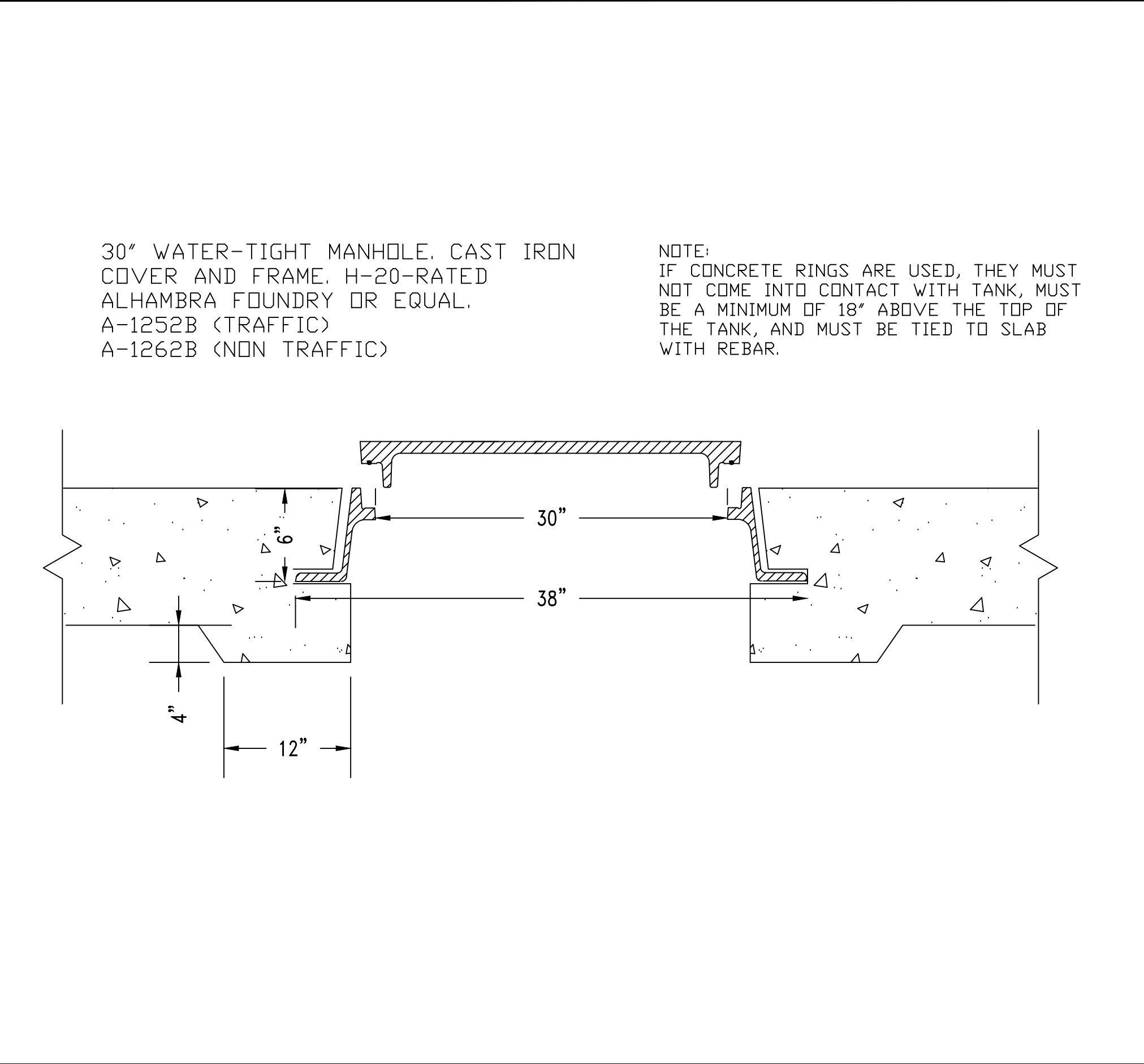

SCALE NONE 3

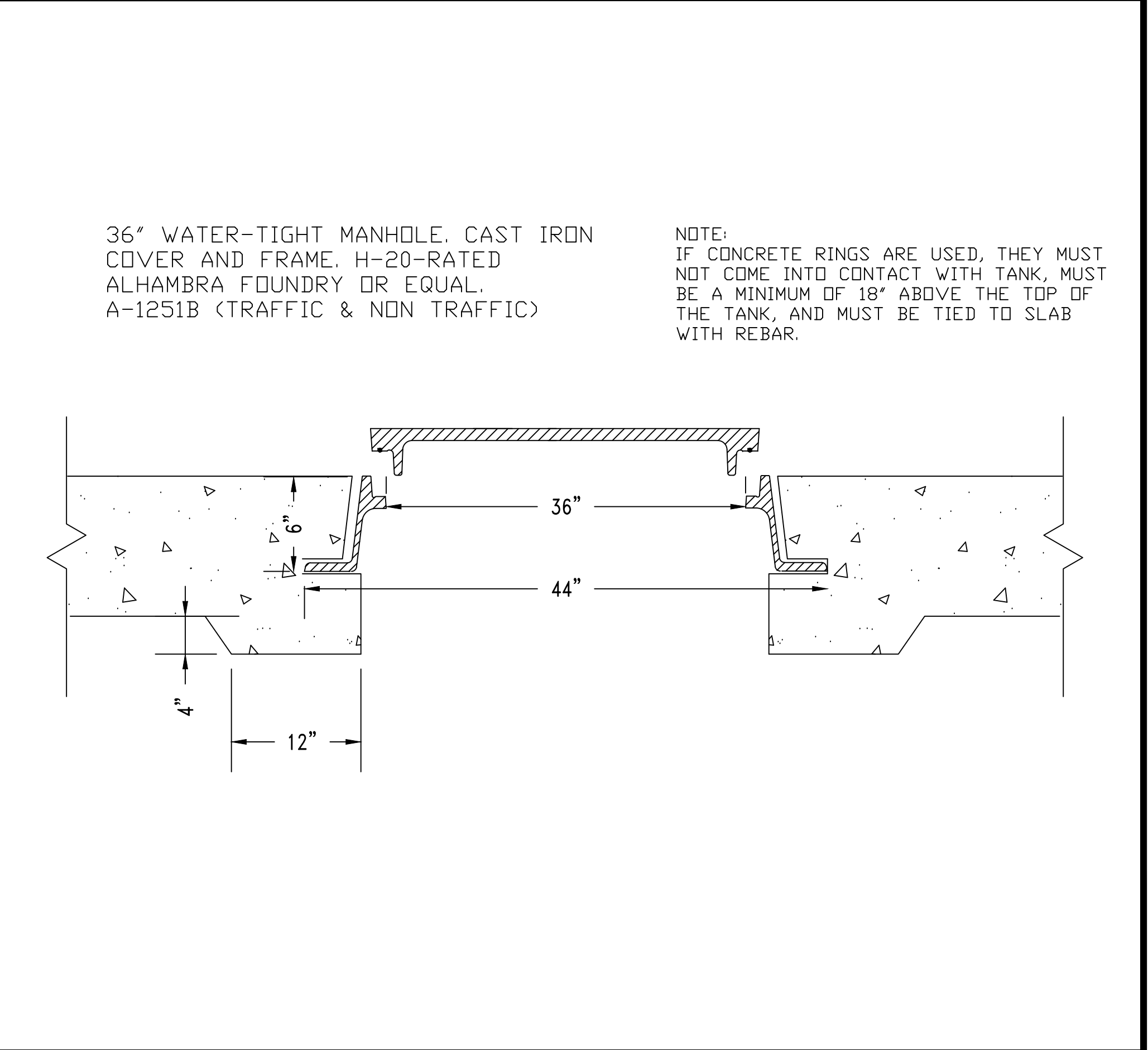

SCALE NONE 4

ANCHOR DETAIL

SCALE NONE 2

MANHOLE DETAIL FOR 24" RISER

MANHOLE DETAIL FOR 30" RISER

SCALE NONE 4

DRAWN:	DATE:	JOB NUMBER:
AJM	2/10/21	ES25 INSTALLATION

REVISION:		
REVISION:	DATE:	DESCRIPTION:

SITE INFORMATION:

ES 25
 INSTALLATION DRAWING

SHEET TITLE:

H20 TRAFFIC SLAB WITH
 ANTI-FLOATATION ANCHORS

SHEET NUMBER:

IN25-09

NOTES

- GENERAL:
- THE MIDDLE THREE CHAMBERS SHOULD NEVER BE PUMPED DRY, ESPECIALLY IN HIGH GROUNDWATER CONDITIONS
 - RISERS AND RISER ADAPTERS NOT SUPPLIED BY MICROSEPTEC
 - PLUMBING DIMENSIONS FROM OUTSIDE EDGE OF TANK TO INVERT OF INLET AND OUTLET
 - CONTRACTOR TO PROVIDE ADDITIONAL PLUMBING FOR ANY BURIAL DEPTH GREATER THAN 4FT
 - SITE-SPECIFIC CHARACTERISTICS INCLUDING BUT NOT LIMITED TO: BURIAL DEPTH, TRAFFIC OR OTHER EXTERNAL LOADING, SEASONAL GROUNDWATER, AND SOIL CHARACTERISTICS SHOULD BE CONFIRMED WITH A LOCAL DESIGN ENGINEER BEFORE INSTALLATION
- TANK BURIAL:
- THE DESIGNED TANK BURIAL DEPTH IS 2FT TO 6FT. ANY TANK BURIED BEYOND THAT RANGE MUST BE ANALYZED BY A LOCAL DESIGN ENGINEER
 - ENGINEERED BACKFILL TO BE A MINIMUM OF 12" ALONG SIDES AND BOTTOM OF TANK
 - GEOLOGIST OR GEOTECHNICAL ENGINEER TO DETERMINE IF ANCHORS AND TEXTILE FILTER ARE REQUIRED
 - DEPTH OF SOIL SLOPE CUT PER LOCAL CODE OR SOIL REPORT
 - VERTICAL CUT FOR FILL HEIGHT CAN BE DONE IF APPROVED BY LOCAL CODE OR SOIL ENGINEER
 - GEOLOGIST OR GEOTECH ENGINEER SHOULD DETERMINE IF CORROSIVE RESISTANT MATERIAL SHOULD BE USED IN ANY STEEL PARTS EXPOSED IN THE SOIL. SEE SHEET IN25-01
- ANCHORING:
- ANCHORING AND ANTI-FLOATATION DESIGNS ARE NOT A ONE-SIZE-FITS-ALL DESIGN AND CONSIDER THE FOLLOWING CONDITIONS:
 - AT LEAST 2FT OF COVER
 - GROUNDWATER AT GRADE
 - MIDDLE THREE TANK CHAMBERS ARE 1/2 FULL OF WATER
 - TO DETERMINE THE EQUIVALENT FLUID WEIGHT OF EARTH OVER TOP OF THE TANK AND COUNTERWEIGHT, A GEOTECH ENGINEER OR OTHER PROFESSIONAL SHOULD BE CONSULTED
 - CONTROL JOINTS FOR ANCHORS ARE DETERMINED BY GENERAL CONTRACTOR

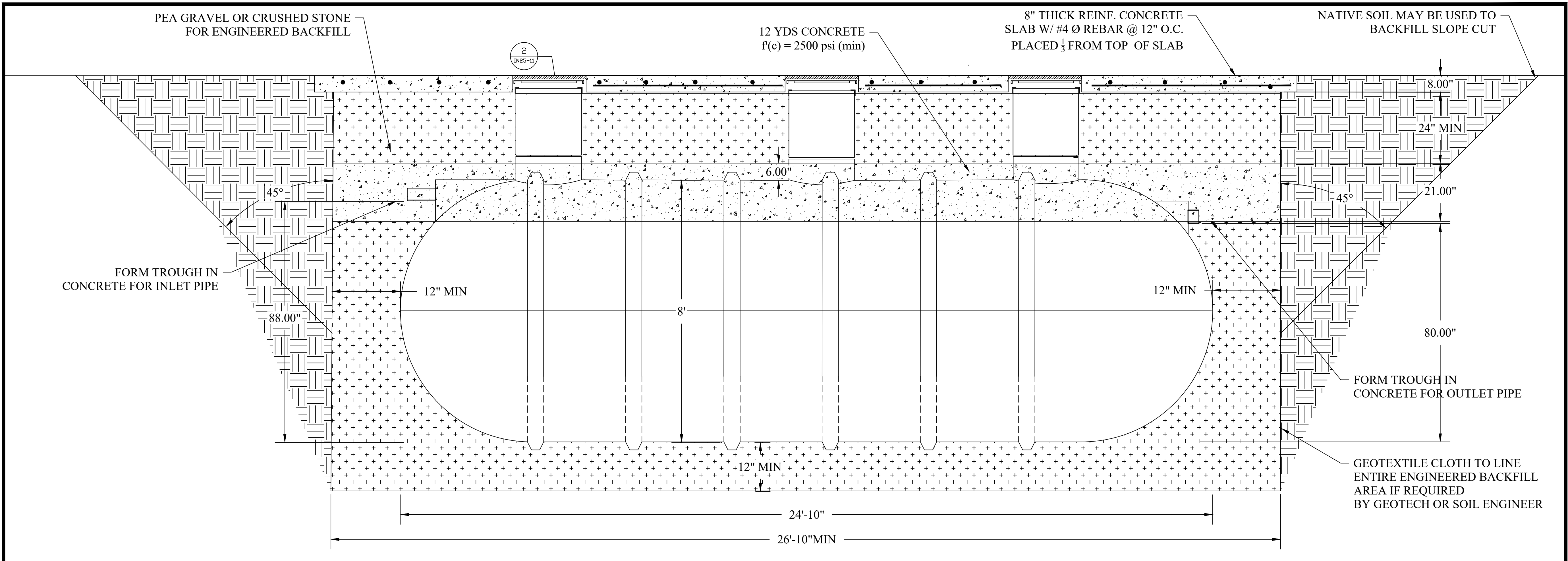

TANK INSTALLATION LAYOUT (ELEVATION VIEW)

SCALE NONE 1

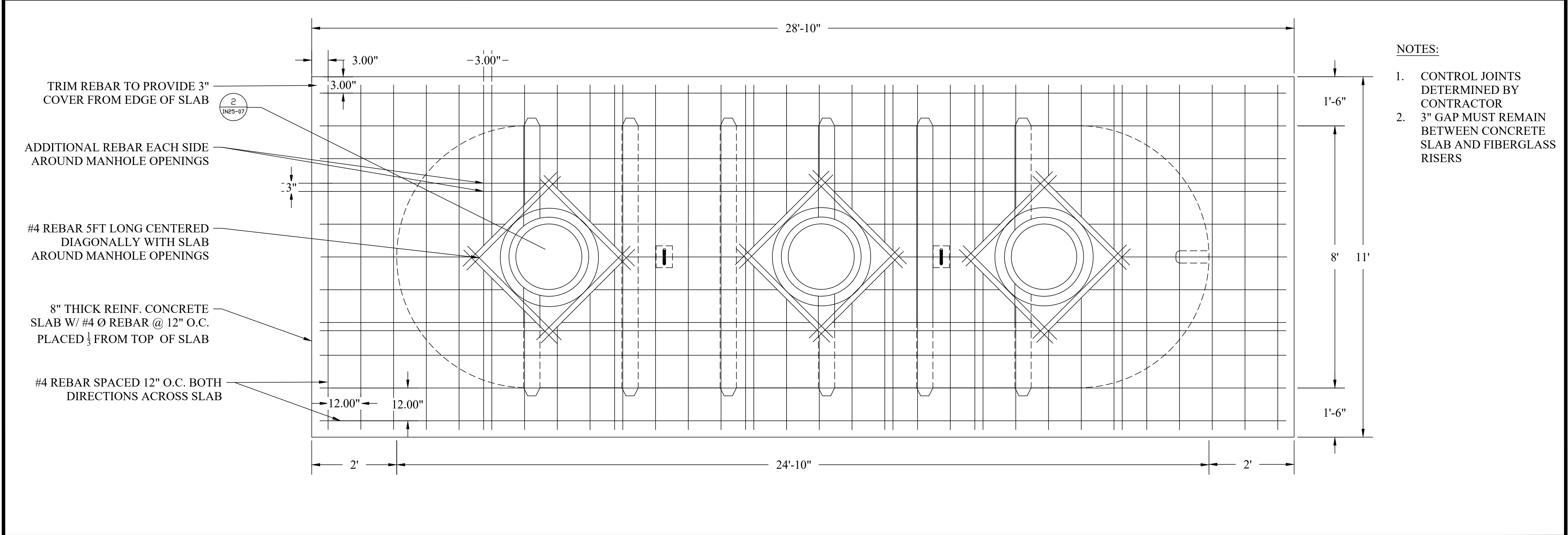

- NOTES:
- CONTROL JOINTS DETERMINED BY CONTRACTOR
 - 3" GAP MUST REMAIN BETWEEN CONCRETE SLAB AND FIBERGLASS RISERS

TANK INSTALLATION LAYOUT (PLAN VIEW)

SCALE NONE 2

DRAWN:	DATE:	JOB NUMBER:
AJM	2/10/21	ES25 INSTALLATION

REVISION:		
REVISION:	DATE:	DESCRIPTION:

SITE INFORMATION:

ES 25
 INSTALLATION DRAWING

SHEET TITLE:

H2O TRAFFIC SLAB WITH
 ANTI-FLOATATION COLLAR

SHEET NUMBER:

IN25-10

NOTES

- GENERAL:
- THE MIDDLE THREE CHAMBERS SHOULD NEVER BE PUMPED DRY, ESPECIALLY IN HIGH GROUNDWATER CONDITIONS
 - RISERS AND RISER ADAPTERS NOT SUPPLIED BY MICROSEPTEC
 - PLUMBING DIMENSIONS FROM OUTSIDE EDGE OF TANK TO INVERT OF INLET AND OUTLET
 - CONTRACTOR TO PROVIDE ADDITIONAL PLUMBING FOR ANY BURIAL DEPTH GREATER THAN 4FT
 - SITE-SPECIFIC CHARACTERISTICS INCLUDING BUT NOT LIMITED TO: BURIAL DEPTH, TRAFFIC OR OTHER EXTERNAL LOADING, SEASONAL GROUNDWATER, AND SOIL CHARACTERISTICS SHOULD BE CONFIRMED WITH A LOCAL DESIGN ENGINEER BEFORE INSTALLATION

- TANK BURIAL:
- THE DESIGNED TANK BURIAL DEPTH IS 2FT TO 6FT. ANY TANK BURIED BEYOND THAT RANGE MUST BE ANALYZED BY A LOCAL DESIGN ENGINEER
 - COVER TO BE A MINIMUM OF 2FT
 - ENGINEERED BACKFILL TO BE A MINIMUM OF 12" ALONG SIDES AND BOTTOM OF TANK
 - GEOLOGIST OR GEOTECHNICAL ENGINEER TO DETERMINE IF ANCHORS AND TEXTILE FILTER ARE REQUIRED
 - DEPTH OF SOIL SLOPE CUT PER LOCAL CODE OR SOIL REPORT
 - VERTICAL CUT FOR FILL HEIGHT CAN BE DONE IF APPROVED BY LOCAL CODE OR SOIL ENGINEER
 - GEOLOGIST OR GEOTECH ENGINEER SHOULD DETERMINE IF CORROSIVE RESISTANT MATERIAL SHOULD BE USED IN ANY STEEL PARTS EXPOSED IN THE SOIL. SEE SHEET IN25-01

- ANCHORING:
- ANCHORING AND ANTI-FLOATATION DESIGNS ARE NOT A ONE-SIZE-FITS-ALL DESIGN AND CONSIDER THE FOLLOWING CONDITIONS:
 - AT LEAST 2FT OF COVER
 - GROUNDWATER AT GRADE
 - MIDDLE THREE TANK CHAMBERS ARE $\frac{1}{2}$ FULL OF WATER
 - TO DETERMINE THE EQUIVALENT FLUID WEIGHT OF EARTH OVER TOP OF THE TANK AND COUNTERWEIGHT, A GEOTECH ENGINEER OR OTHER PROFESSIONAL SHOULD BE CONSULTED
 - CONTROL JOINTS FOR ANCHORS ARE DETERMINED BY GENERAL CONTRACTOR

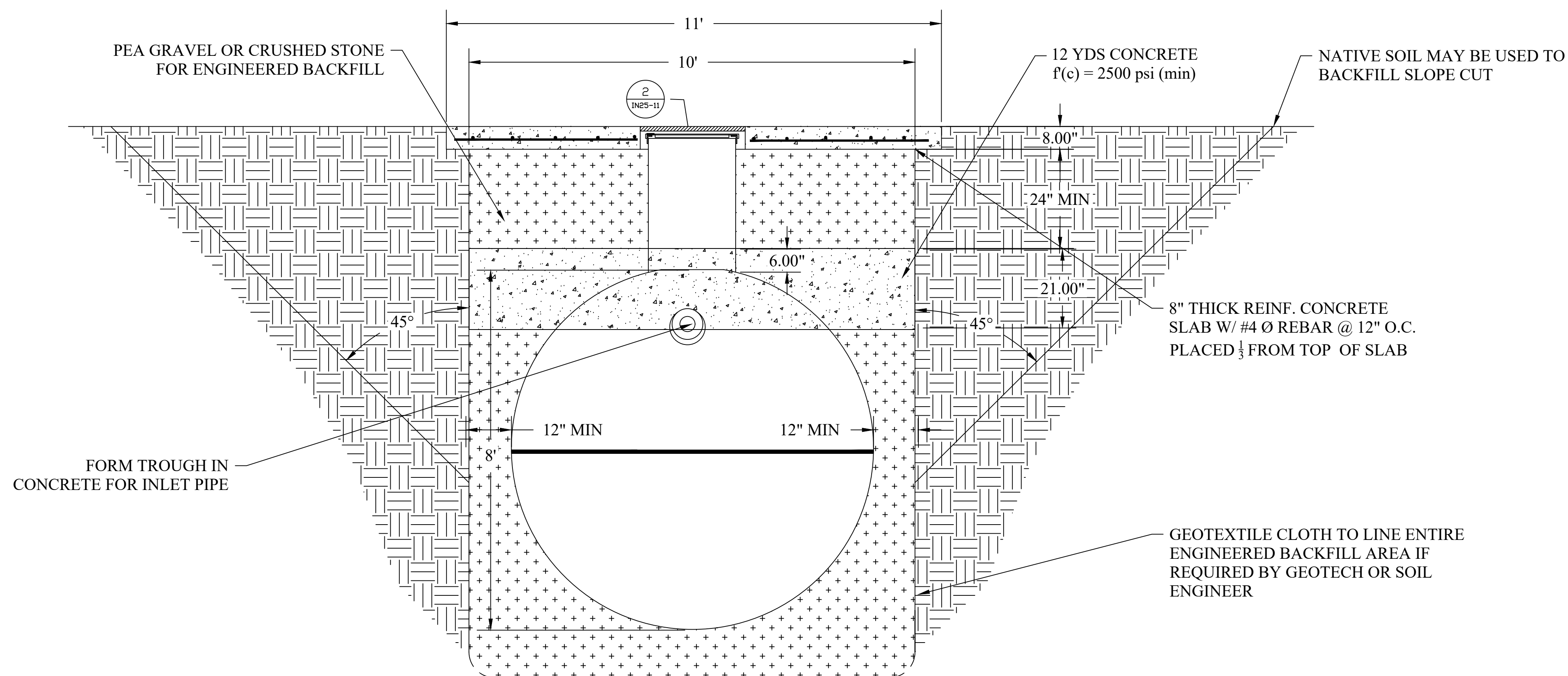

TANK INLET VIEW

SCALE NONE 1

30" WATER-TIGHT MANHOLE. CAST IRON COVER AND FRAME. H-20-RATED ALHAMBRA FOUNDRY OR EQUAL. A-1252B (TRAFFIC) A-1262B (NON TRAFFIC)

NOTE: IF CONCRETE RINGS ARE USED, THEY MUST NOT COME INTO CONTACT WITH TANK, MUST BE A MINIMUM OF 18" ABOVE THE TOP OF THE TANK, AND MUST BE TIED TO SLAB WITH REBAR.

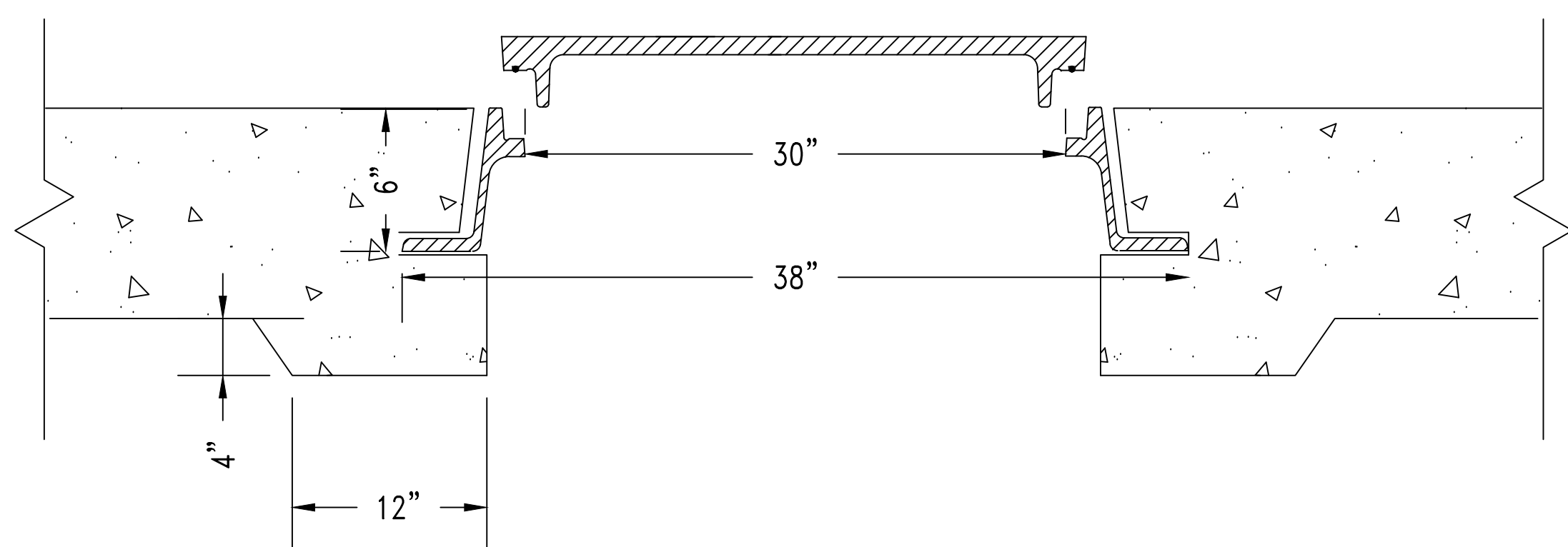

MANHOLE DETAIL FOR 24" RISER

SCALE NONE 2

36" WATER-TIGHT MANHOLE. CAST IRON COVER AND FRAME. H-20-RATED ALHAMBRA FOUNDRY OR EQUAL. A-1251B (TRAFFIC & NON TRAFFIC)

NOTE: IF CONCRETE RINGS ARE USED, THEY MUST NOT COME INTO CONTACT WITH TANK, MUST BE A MINIMUM OF 18" ABOVE THE TOP OF THE TANK, AND MUST BE TIED TO SLAB WITH REBAR.

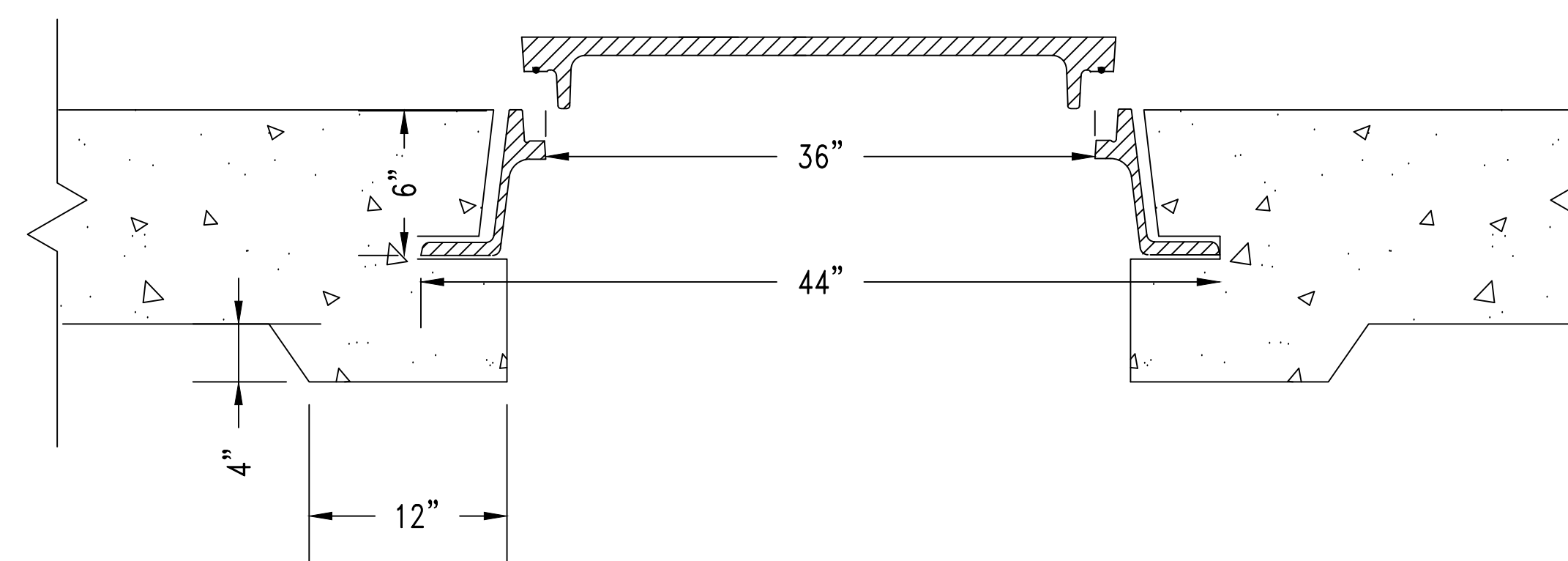

MANHOLE DETAIL FOR 30" RISER

SCALE NONE 3

DRAWN:	DATE:	JOB NUMBER:
AJM	2/10/21	ES25 INSTALLATION

REVISION:		
REVISION:	DATE:	DESCRIPTION:

SITE INFORMATION:
 ES 25
 INSTALLATION DRAWING

SHEET TITLE:
 H20 TRAFFIC SLAB WITH
 ANTI-FLOATATION COLLAR

SHEET NUMBER:
 IN25-11