



MicroSepTec
www.microseptec.com



INSTALLATION MANUAL

ONE TANK - FIVE CHAMBERS - TOTAL TREATMENT

©2021 MicroSepTec REV052121



This Page left blank intentionally for two sided printing

Table of Contents

General Information	2
Glossary of Terms	2
What is the MicroSepTec EnviroServer ES System?	4
Major Components	4
Scientific and Engineering Principles	6
EnviroServer Process	7
Treated Effluent Quality	9
Safeguards	9
Range of Operating Conditions	10
Extended Periods of Non-Use	10
Water Conservation	10
Do Not Flush	11
References	11
MATERIALS SUPPLIED BY MICROSEPTEC	12
Base Assembly	12
Air Supply Assembly	12
Control Configuration	12
Fragile components	12
Options	12
Ordering Replacement Parts	12
System layout	13
Venting	13
Water Softeners	13
Power supply	13
Site requirements	14
General	15
Installer responsibilities	15
Tank Shipping, Unloading, Inspection and Storage	15
Backfill Specifications:	16
Approved primary backfill materials	17
Pea Gravel	17
Crushed Stone	17
Secondary Backfill Specification	17
Select Native Backfill	17
Excavation	17
Minimum Excavation Requirements	18
Burial Depth	18
Tank Spacing	18
Filter Fabric Liner	18
Tank Anchors	19
Deadmen	19
Tie Downs	19
ANTI-FLOTATION COLLAR	19

Backfilling	20
Dry-Hole Installation	20
Wet-Hole Installation	21
Watertight testing	22
Procedures for watertight testing	22
Cold Weather	23
Tank Insulation	23
Internal Component Installation	25
Components in Second Riser	25
Riser Installation	27
Single compressor Air Supply Kit	28
Double compressor Air Supply Kit	28
Components in Third Riser	31
RISER ADAPTER INSTALLATION	32
Riser Installation	32
Junction Box Penetrations	34
INTERNAL MOUNT	35
THROUGH-RISER PENETRATION	35
RUN CABLES AND AIRLINES	35
THROUGH-RISER PENETRATION	36
Run cables AND AIRLINES	36
FLOAT TREE MOUNTING BRACKET	37
Installing floats on float holders	38
Installing float holders on Float tree	38
Airlift Assembly and Installation	40
Airlift Recirculation Pump Assembly Installation	40
Mechanical Recirculation Pump Installation (Optional)	42
Plumbing	42
Electrical	42
Recirculation Valve	42
Pressure Switch Connections	42
CONDUIT TO ALARM CONTROL PANEL	43
RUN CABLES AND AIRLINES	43
Control Panel Installation	43
Compressor location	44
Placing the compressor	44
Plumbing from the compressor	44
Limited Warranty	46

General Information

Thank you for selecting the EnviroServer® ES Series Wastewater Treatment System. Sometimes, the simplest solution is the best and that's the case with the EnviroServer. Simple, because the entire treatment system is in one tank. Simple, because the only moving part is the compressor. Simple, because there is minimal intrusion to the landscape. Simple, because the process is accomplished with aeration and agitation, the same technology as sewer treatment plants. Simply simple!

The system employs a naturally occurring biological process. Although it is robust, certain care must be taken. This manual will let you know what the EnviroServer ES Series is, how it works, and what is needed to keep it operational and healthy for as long as you own it. Please read through the entire manual and familiarize yourself with all maintenance recommendations, safeguards, and care instructions. Remember to educate members of your household and guests about the system, paying attention to the safeguards.

Glossary of Terms

Air Diffusers: Membrane device used to evenly distribute fine air bubbles in order to transfer and mix oxygen with dissolved substrates.

Alarm Control Panel: Controls the process and indicates failures of mechanical and electrical components.

Back-Flush System: Used with a drip dispersal system. A series of valves and a filter used downstream from the EnviroServer to flush the drip line filter and field.

Coliform Bacteria: Group of bacteria that constitute most of the intestinal flora of warm-blooded animals (including the genera *Klebsiella* sp., *Enterobacter* sp., *Citrobacter* sp., or *Escherichia* sp.) and are used as water pollution indicator organisms.

Coliform Bacteria, fecal: Indicator bacteria common to the digestive systems of warm-blooded animals that is cultured in standard tests to indicate either contamination from sewage or the level of disinfection; generally measured as number of colonies/100 mL or most probable number (MPN).

Coliform, total (TC): Measurement of water quality expressed as the number of colony-forming units (cfu) of coliform bacteria per unit volume.

BOD (Biochemical Oxygen Demand): The amount of dissolved oxygen needed (i.e. demanded) by aerobic biological organisms to break down organic material present in each water sample at a certain temperature over a specific time period. The BOD value is most expressed in milligrams of oxygen consumed per liter of sample during 5 days of incubation at 68°F and is often used as a surrogate of the degree of organic pollution in water.

CBOD (Carbonaceous BOD): A subset of BOD. BOD results are based on DO depletion from both carbonaceous and nitrogenous actors in a wastewater sample. CBOD measures DO depletion from only carbonaceous sources. Concentrations of oxygen utilized by microorganisms in the oxidation of organic matter during a 5-day period at 68°F. BOD is measured to indicate the strength of wastewater and/or the effectiveness of treatment. This is the unit measurement used in NSF/ANSI testing of treated wastewater systems.

Discharge Pump: A pump used to discharge processed water from the last chamber to the dispersal area.

Disinfection: Process used to destroy or inactivate pathogenic microorganisms in wastewater to render them noninfectious.

Disinfection, ultraviolet (UV): Process used to inactivate microorganisms by irradiating them with ultraviolet light to disrupt their metabolic activity, thus rendering them incapable of reproduction.

Dispersal: Spreading of effluent over and into the final receiving environment.

Distribution: The process of conveying wastewater or effluent to one or more components or devices.

Drip Dispersal: Application of effluent over an infiltrative surface via pressurized emitters and associated devices and parts (pump, filters, controls, and piping).

Effluent: Treated wastewater that flows out of the system.

EnviroServer ES System: An advanced wastewater treatment system that employs a hybrid fixed-film, suspended growth, extended aeration process (MBBR) that utilizes a two-stage biological process to optimize nitrification and denitrification.

ES (Extended Storage): The extended amount of storage volume of the EnviroServer ES Series.

Influent: Wastewater flowing into the system.

FOG (fats, oils, and grease): Constituent of sewage typically originating from foodstuffs (animal fats or vegetable oils) or consisting of compounds of alcohol or glycerol with fatty acids (soaps and lotions), typically measured in mg/L.

MBBR (Moving Bed Biological Reactor): A type of wastewater treatment process that consists of an aeration tank (like an activated sludge tank) with special plastic carriers that provide a surface where a bio-film can grow. To achieve higher concentration of biomass in the bioreactors, hybrid MBBR systems (like the EnviroServer) are used where suspended and

attached biomass co-exist, contributing both to biological processes.

Normally Closed (NC): An alarm circuit that will not report an alarm when the circuit is closed; opening of the circuit (e.g. disconnecting wire, an open float or pressure switch) creates an alarm.

Normally Open (NO): An alarm circuit that will not report an alarm when the circuit is open; closure of the circuit (e.g.. a jumper, a closed float or pressure switch) creates an alarm.

Recirculation Pump: A pump used to return sludge and nitrified water from the final clarifier to the primary clarifier. The EnviroServer uses an air-actuated pump as its standard or an optional mechanical recirculation pump.

Telemetry System: A system that remotely monitors the process by delivering alarm signals to a remote Internet server.

Nitrogen (N): Essential chemical element and nutrient for all life forms; molecular formula (N_2), constitutes 78 percent of the atmosphere by volume; nitrogen is present in surface water and groundwater as ammonia (NH_3), nitrite (NO_2^-), nitrate (NO_3^-), and organic nitrogen; excess levels of nitrogen in marine areas may contribute to eutrophication.

Nitrogen, ammonia (NH_3): Non-ionized form of reduced nitrogen. Nitrogen, ammonium (NH_4^+): ionized form of reduced nitrogen usable by plants.

Nitrogen, Kjeldahl: Combination of ammonia nitrogen (NH_3) and organic nitrogen in a wastewater sample; total Kjeldahl nitrogen is operationally defined by a method that involves digestion of a sample followed by distillation and determination of ammonia (NH_3) in the distillate; see also nitrogen, ammonia; nitrogen, organic; and nitrogen, total Kjeldahl (TKN).

Nitrogen, nitrate (NO_3^-): Stable oxidized form of nitrogen; nitrifying bacteria can convert nitrite (NO_2^-) to nitrate (NO_3^-) in the nitrogen cycle.

Nitrogen, nitrite (NO_2^-): Unstable oxidized form of nitrogen.

Nitrogen, organic: Nitrogen bound in plant and animal matter, primarily amino acids and proteins; the amount of organic Nitrogen can be obtained by separately measuring the ammonia nitrogen and subtracting that value from the total Kjeldahl nitrogen.

Nitrogen, total: Measure of the complete nitrogen content in wastewater including nitrate (NO_3^-), nitrite (NO_2^-), ammonia (NH_3), ammonium (NH_4^+), and organic nitrogen, expressed as mg/L of N; all these forms of nitrogen, (as well as nitrogen gas [N_2]), can be biochemically converted from one form to another and are constituents of the nitrogen cycle.

Nitrogen, total Kjeldahl (TKN): Measure of the total concentration of organic nitrogen, ammonia, and ammonium nitrogen.

TSS (Total Suspended Solids): The quantity of solids, which can be readily removed from a well-mixed sample with standard laboratory filtering procedures. TSS is measured to indicate the strength of wastewater and/or the effectiveness of treatment.

Toxic event: Sudden introduction of a substance or substances that impair or destroy biological activity within a wastewater treatment process.

Wastewater. The spent or used water of a structure containing dissolved and suspended matter.

Wastewater, commercial: Non-toxic, non-hazardous wastewater from commercial establishments, including but not limited to commercial food preparation operations, that is similar in composition to domestic wastewater, but which may have one or more of its constituents exceed typical domestic ranges.

Wastewater, domestic: Water or liquid carried waste from plumbing fixtures, appliances, and devices such as toilets, bath, laundry, and dishwashers.

Wastewater, high-strength: influent having BOD greater than 300 mg/L and/or TSS greater than 350 mg/L and/or fats, oils, and grease greater than 50 mg/L.

Wastewater, residential strength: Wastewater generated from a household that is not being used as a home business, in-home health care facility, beauty shop, taxidermy shop, or any other use that would be considered commercial use. Typical residential strength waste has a strength of 100-300 mg/L of BOD and a TSS of 100-350 mg/L and fats, oils, and grease less than or equal to 25 mg/L.

Wastewater Treatment System, on-site (OWTS): Wastewater treatment system relying on natural processes and/or mechanical components to collect and treat sewage from one or more dwellings, buildings, or structures and disperse the resulting effluent on property owned by the individual or entity.

What is the MicroSepTec EnviroServer ES System?

The EnviroServer ES is a pre-engineered, prefabricated MBBR on-site wastewater treatment system that is typically used in areas where sewer is not available and septic systems are not permissible due to environmental concerns. The system uses an accelerated natural biological process for wastewater treatment in a single tank design without employing any chemical or biological additives. The EnviroServer ES is engineered for dependability and proven reliability. It uses a heavy-duty fiberglass tank, which is the preferred method of storage for volatile fluids like gas and oil, and it employs industrial compressors and pumps (when needed) that function reliably for many years. The system is based on simple “plug and play” concepts to allow for quick installation and maintenance, with a minimum of moving parts.

The EnviroServer ES was the first small package residential MBBR product available in a self contained single tank. As a result, it requires minimal excavation which reduces installation costs and it can be installed in lots with space constraints. The tank leaves a very small footprint, which can be camouflaged with flagstone, fake rocks, etc. while maintaining easy access for future maintenance of the system. There are no large, unsightly boxes or lids visible in the landscape. The tank can also be installed in traffic-rated situations with minimal special requirements.

Because the compressor is the only moving part, minimal upkeep is required. Routine maintenance and inspections are mandatory to meet warranty requirements. Regulatory agencies may have additional requirements above the minimum required by MicroSepTec. Typically, maintenance is performed on the EnviroServer in about an hour, keeping operational costs low. MicroSepTec trained and authorized personnel must complete the installation, startup, inspections, service, and maintenance of the EnviroServer unit.

When properly designed, installed, and maintained, there are no sewer gas smells with the EnviroServer ES. This is because it uses high-efficiency, low-flow compressors that run continuously and with no noticeable noise.

Optional equipment includes mechanical recirculation pump, ultra-violet disinfection, and telemetry. The system can be configured to meet the needs of each specific site, including discharge pump(s), depending on the options required and the location of the components.

Major Components

Aeration Diffusers: The two membrane air diffusers are in the bottom of the second and third compartments and are supplied air from external air compressors. The diffusers transfer dissolved oxygen to the chamber and agitate the biomedica and suspended solids for rapid bacterial digestion of organic matter.

Alarm Control Panel: The EnviroServer is equipped with a series of alarms. These alarms are:

High-Level Alarm: Triggers when the water level in the effluent chamber is too high. The local indicator is the High-Level Alarm light and an audible alarm. If the system contains a telemetry monitoring system, the service provider will automatically be notified when the condition occurs.

Low Air Alarm: Triggers when there is a loss of air pressure. The local indicator is the Low Air Alarm light and an audible alarm. If the system contains a telemetry monitoring system, the service provider will automatically be notified when the condition occurs.

UV Alarm (optional): Triggers when there is a UV lamp failure and/or when the lamp is not transferring enough ultraviolet radiation to be effective and needs to be replaced. The local indicator is the UV Alarm light and an audible alarm. If the system contains a telemetry monitoring system, the service provider will automatically be notified when the condition occurs.

Power Failure: Is indicated when the green light on the front of the panel is not illuminated.

Spare Alarm: Is triggered when the spare alarm contact is open. The local indicator is both the high-level and low air lights, together, and audible alarm active. If the system contains a telemetry monitoring system, the service provider will automatically be notified when the condition occurs.

Remote Alarm Input: The system has a remote alarm input that allows alarms (120V input) from a remote panel to connect through the EnviroServer Panel. This interface has no local alarms and only sends a signal to the optional telemetry unit.

Communication Failure (with telemetry option): No local notifications. Will have blinking lights on the telemetry board inside the panel and will notify the service provider of the failure once this condition occurs.

Biomedica: Plastic media used in the MBBR to help promote the attachment and growth of bio-films and high biologically active organisms that are used to treat wastewater.

High-Level Float: Activates an audible alarm and the red light on the front of the panel. If equipped with telemetry remote notification, an alert will be sent to the service provider.

Peak Float (included with discharge pump control panels): Activates the discharge pump(s) regardless of timer settings. If duplex discharge pumps are required, this float operates the second pump rather than overriding the timer on the first pump. If the system contains a telemetry monitoring system, the service provider will automatically be notified when the condition occurs.

On/Off (timer enable) (included with discharge pump control panels): Activates the pump in a demand-dose application or enables the timer in a time-dose application.

Redundant Off (optional with discharge pump control panels): Deactivates discharge pumps when the water level is too low to prevent the pump from running dry and activates an audible alarm. If equipped with telemetry remote notification, an alert will be sent to the service provider.

Compressors: Air compressors provide air to the diffusers and the airlift recirculation pump. The ES6 uses one compressor and both the ES12 and ES25 use two compressors. Since airflow is the key to the proper function of the system, the compressors run continuously.

Discharge Pump (optional): A discharge pump is used when gravity flow from the system is not adequate. These pumps are powered through a PLC controlled by the Alarm Control Panel and floats.

Recirculation:

Airlift Pump (standard): This pump resides in the fourth compartment; it recirculates water and biomass back to the first compartment. The pump has no moving parts and uses air to lift the water and siphon it through piping back to the first chamber. The rate of recirculation is controlled by a needle valve that controls the volume of air provided to the pump. The pump should recirculate 8-10% of the system capacity per hour. The needle valve should be adjusted at service intervals depending on actual system loading. Not recommended for denitrification systems.

Solenoid Controlled Airlift Pump (optional): This pump resides in the fourth compartment; it recirculates water and biomass back to the first compartment. The pump has no moving parts and uses air to lift the water and siphon it through piping back to the first chamber. The rate of recirculation is controlled by a solenoid valve that controls the volume of air provided to the pump and is controlled by a timer in the control panel to recirculate 8-10% of the system capacity per hour. The solenoid timer should be adjusted at service intervals depending on actual system loading.

Mechanical Recirculation Pump (MRP) (optional): The Mechanical recirculation pump can be used instead of the airlift pump. It is installed in the fourth compartment and recirculates water and biomass back to the first compartment. This pump is controlled by a timer that is included in the control panel to recirculate 8-10% of the system capacity per hour. The MRP timer should be adjusted at service intervals depending on actual system loading.

Pressure Switches: The EnviroServer is equipped with one or two pressure switches that monitor the air pressure from the compressors to the air diffusers and airlift pump. The pressure switches are mounted in a junction box in or near the third riser of the tank.

Silent/Test Selector: This switch is mounted on the exterior of the controller door and is used to test all alarms and silence an audible alarm. Moving the switch to the 'Test' position will turn on the audible alarm and alarm lights. Moving the switch to the 'Silent' position will turn off the audible alarm when buzzing.

Telemetry (optional): The telemetry system monitors all alarm conditions in addition to system power outages. If any alarm condition continues for a period, the telemetry system will contact the remote monitoring computer. The remote computer will log the alarms and alert the service provider with text and email messages.

UV disinfection (optional): UV disinfection is a physical process that instantaneously neutralizes microorganisms as they pass by ultraviolet lamps submerged in the effluent.

Scientific and Engineering Principles

The design of the EnviroServer ES Model is based on well-known engineering principles in the wastewater field applied in a new way. The system can be described as a hybrid fixed-film, suspended growth, extended aeration wastewater treatment system with a two-stage biological process to optimize denitrification. This system is also referred to as a Moving Bed Biological Reactor (MBBR). The treatment portion of the ES Model is the same as the patented¹ and certified² EnviroServer SM Model. The ES Model is equipped with a larger Primary Clarifier Compartment for Extended Storage (ES) of sludge in lieu of the Thermal Processor for Solids Management (SM), which is part of the SM Model.

The EnviroServer ES removes nitrogen using biological processes; specifically, ammonification followed by nitrification and denitrification. In ammonification, organic nitrogen (proteins and peptides) is decomposed to ammonia or ammonium ions. About 80% of the ammonification takes place in the sewer lines before the wastewater enters the EnviroServer and the balance is ammonified in the first compartment. The ammonification is followed by nitrification. In nitrification, ammonia is removed biologically by a two-step process in which the ammonia is oxidized to nitrite and then the nitrite is oxidized to nitrate according to the following formulas (^{3, 8, 13}).

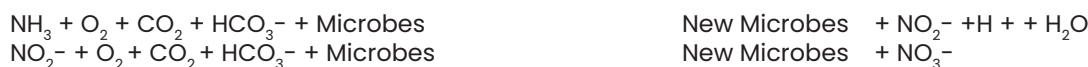

The nitrification is affected by temperature, pH, dissolved oxygen (DO), alkalinity, contact time, and mean cell residence time (^{4, 6, 13}). Influent pH ranges between 7.5-8.0 are required for denitrification. The temperature and pH are not specifically controlled in the EnviroServer. The temperature is normally kept between 70 and 90°F by the microbial activity and some added heat from the air compressor(s). The pH is typically between 7.0 and 8.5 in the EnviroServer, since no chemicals are added to any of the compartments. In the EnviroServer, under normal operations, both the temperature and the pH fall well within the optimum range for nitrification.

Air is continuously supplied to the two aerobic compartments in the tank to keep the dissolved oxygen above 3 mg/l. The conversion of ammonia to nitrates requires 4.57 kg of oxygen per kg of ammonia converted (^{12, 15, 16}). Furthermore, it requires about 7 mg of carbonate alkalinity per mg of ammonia nitrogen (⁸). The alkalinity concentration in the tap water is typically enough to convert all the ammonia to nitrates, but in some cases, an alkalinity source must be added. Nitrate formed during nitrification is removed by heterotrophic organisms under anaerobic conditions by converting it to gaseous nitrogen species through denitrification (^{13, 15, and 16}). In this process, nitrate is first reduced to nitrite and then to nitric oxide (NO), followed by nitrous oxide (N₂O), and nitrogen gas (N₂). This process requires a carbon source. In the EnviroServer, the wastewater exiting the two-stage aerobic section is high in nitrates and low in carbon. It is recirculated back to the first anaerobic compartment where it mixes with the raw wastewater, which is high in carbon. Denitrification requires 5-6 mg of BOD per mg of Nitrate-Nitrogen removed, and it produces about 3 mg of carbonate alkalinity per mg of Nitrate-Nitrogen removed.

The biodegradable organic carbon that causes CBOD is converted to carbon dioxide and settleable biomass by heterotrophic organisms¹³. These microorganisms require oxygen. The process is referred to as aerobic digestion and can be expressed by the following equation (^{7, 12}).



The aerobic digestion takes place in the second compartment of the EnviroServer. The EnviroServer utilizes a combination of an attached and suspended growth process. The attached film is growing on a biomedium and the suspended growth is created by mixing and recirculation of sludge. This combination results in a treatment efficiency that exceeds the individual performance of either an attached or suspended growth process. The aerobic digestion of organic matter is mainly affected by dissolved oxygen, pH, temperature, mixing, and solids retention time. The design of the EnviroServer optimizes these parameters for maximum CBOD₅ and nitrogen removal (^{5, 6, 7, 10}).

The fourth compartment is the clarifier where final settling of suspended solids and clarification of the effluent takes place. The settled solids are then recirculated back to the first compartment. The fourth compartment is followed by an effluent storage compartment which can be equipped with an optional gravity flow UV disinfection unit and/or an effluent pump. UV disinfection is recommended for shallow dispersal fields, such as drip dispersal.

The tank design is optimized with respect to the following parameters: wastewater flow rate, sludge settling rate, sludge removal, surface area, tank depth, overflow rate, inlet device, and tank configuration (⁹).

EnviroServer Process

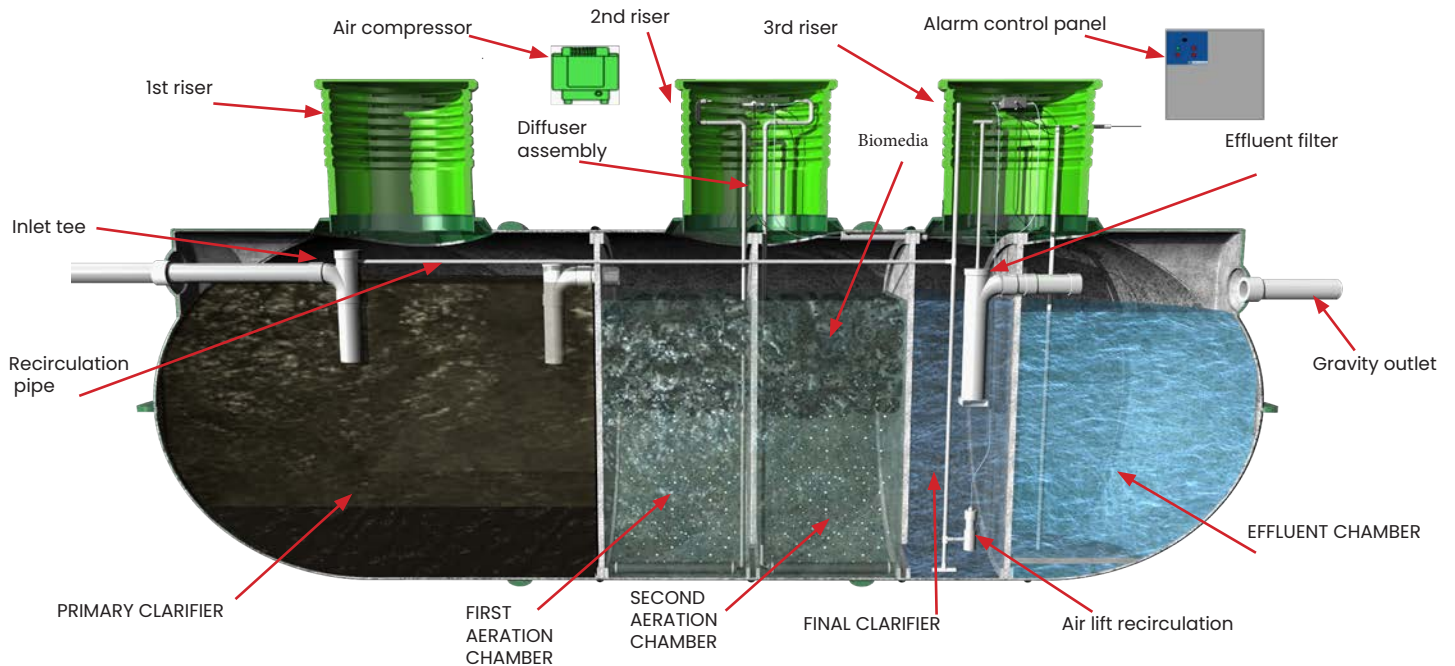

Stage 1 – Primary Clarification

The figure above shows a process flow diagram of the EnviroServer ES Model. Wastewater influent from the house is gravity fed into the first compartment (Primary Clarifier) of the system. In the first compartment, settling of the sludge and solids occurs. The primary clarified wastewater flows into the second compartment of the system (First Aeration Chamber) through sanitary tees.

Stage 2 – Biological Organic Removal

In the second compartment, the wastewater is aerated using a high-efficiency, low-pressure air compressor and a fine-bubble membrane air diffuser assembly. The diffuser assembly is custom-designed to ensure maximum oxygen transfer and optimum mixing of dissolved substrates and oxygen. Furthermore, the mixing ensures the solids remain suspended within the reactor and the biomedia does not clog. The aeration promotes the growth of aerobic microorganisms, which convert and remove biodegradable organic matter. (The organics removed by the aerobic process are the constituents that are measured in the CBOD₅ test.)

To optimize the contact time and the mean cell residence time, the EnviroServer utilizes a biomedia in the aerobic sections. This plastic media is used to supply a support structure for the establishment of a resident bio-film and is specifically developed for optimized biological growth without clogging. The design allows the biomass to attach to the biomedia and not flush out during high flow rates. The biomedia also enhances the nitrification process, which requires a larger population of organisms due to the lower metabolic rate of the nitrifying bacteria.

Stage 3 – Biological Ammonia Conversion (Nitrification)

The partially treated wastewater, now low in carbon but high in ammonia, flows into the third compartment (Second Aeration Chamber) of the system and is aerated in the same manner as the second compartment. The combination of low carbon content, high ammonia, and high oxygen levels in this chamber promotes the growth of nitrifying microorganisms (Nitrosomonas and Nitrobacter). The nitrifying microorganisms convert ammonia to nitrates utilizing the oxygen in the wastewater.

Stage 4 – Clarification

The two-stage aerobically treated wastewater, which is now high in nitrates but low in carbon (BOD), flows into the fourth compartment (Final Clarifier) of the system where clarification and settling of suspended solids occurs.

Stage 5 – Nitrate Removal

To promote denitrification, the wastewater is recirculated from the final clarifier back to the primary clarifier, which contains enough carbon to promote denitrification. Denitrification occurs because the bacteria in the primary (anoxic) clarifier use the oxygen from the nitrate molecules in their metabolic process; the nitrogen left over from this reaction is then released as a gas.

Stage 6 – Solids Removal

The recirculation also helps prevent accumulation of biomass in the final clarifier, decreasing the need for periodic removal. Removing the accumulated biomass helps ensure optimum clarifier performance, resulting in an effluent with low suspended solids. The transfer of the biomass to the primary clarifier ensures a large vital population of microorganisms for the organic and nitrogen removal processes in the aeration compartments. When the water is recirculated, it carries nutrients from the primary clarifier into the aeration compartments. Thus, the available nutrients are utilized to sustain the population if possible, particularly in times of low loading such as vacation periods. In normal operation, this keeps sludge build-up to a minimum by helping break up and dissolve the solids, thereby making the nutrients available for the microorganisms.

Because of the recirculation, the sludge is accumulated and stored in the primary clarifier. The primary clarifier is sized to hold sludge for one to three years, depending on the usage of the system, and pumping is required as needed.

Stage 7 – Effluent Filtration and Disinfection (optional)

The clarified water leaves the treatment compartments through an effluent filter into the final storage compartment (Effluent Chamber). The effluent filter protects the effluent chamber and subsequent dispersal field from solids carry-over during upset conditions. It is designed to remove all particles larger than 1/16". An UV-disinfection unit can be added to sterilize remaining pathogens, including fecal coliform. When selected, the clarified water passes through a disinfection unit after it leaves the effluent filter. The effluent is now ready for discharge.

Treated Effluent Quality

The EnviroServer has been tested and certified to NSF/ANSI STD 40 Class 1

Parameter	NSF/ANSI Std. 40 certified Class I 30-day average effluent requirements	EnviroServer Average effluent ²
BOD ₅ (mg/L)	25	6
TSS (mg/L)	30	8
PH	6-9	6.2-7.9
TN (mg/L) ³	50% reduction	<25

Note: Only certain models are tested and certified to NSF/ANSI Std. 40 ²Effluent wastewater is a measurement of CBOD₅ ³Results from independent third party testing.

When treating domestic strength sewage as defined by NSF/ANSI with an influent BOD range between 100-300 mg/L and a suspended solids range between 100-350 mg/L TN between less than 70 mg/L, and Fats, Oil and Grease (FOG) under 50mg/L. The EnviroServer system will typically perform better than the 30-day average requirements of NSF/ANSI Standard 40 Class 1 (25 mg/L CBOD₅ and 30 mg/L TSS). Reductions in the BOD₅ and suspended solids (TSS) effluent concentrations will be attained within weeks of commissioning and should be consistently achieved over the lifetime of the EnviroServer with proper maintenance and service.



Safeguards

To reduce the risk of fire, electrical shock, or injury:

- ◇ Do not use any flammable liquids near any portion of the EnviroServer
- ◇ Keep flammable materials and vapors, such as gasoline, away from the EnviroServer
- ◇ Never operate the system with any of the covers opened or removed
- ◇ Do not attempt to open manhole covers

***There are no owner-serviceable parts on the EnviroServer System.
ALL SERVICE MUST BE PERFORMED BY A MICROSEPTec AUTHORIZED PROVIDER.***

Range of Operating Conditions

For the system to perform as intended, the EnviroServer must be properly installed and maintained by a MicroSepTec Authorized service provider. The design flow is based on an average throughout the day; as such, high peak flows can adversely affect the treatment process. Peak flows of greater than 40% of daily design flow in three hour period, 60 % of design flow in a seven hour period, or 100% of design flow in a fourteen hour period without a ten hour period of no load will increase the likelihood of poor performance of the system and should, therefore, be avoided.

Note: The system is designed to treat typical residential influent strength wastewater, 100-300 mg/L BOD, 100-350 mg/L TSS, 30-70 mg/L total Nitrogen (NSF/ANSI standard influent parameters), and FOG under 50 mg/L. Influent strengths greater than the properties stated above will decrease the treatment capacity.

Note: Certain activities in the facility will change the characteristics of the influent and will change the classification from residential to other use. In-home businesses, beauty salons, taxidermy, home breweries, home commercial bakery, and home health care are some examples of in-home activities that would cause the system to function improperly and void the warranty.

Extended Periods of Non-Use

The EnviroServer went through testing protocols under several stress conditions and was effective at continuously meeting effluent standards under these stress conditions. However, like most biological treatment units if there is an extended period of non-use the biological activity in the EnviroServer could diminish in effectiveness.

If the EnviroServer System is used intermittently no special actions are required if the power is on and the system continues to operate.

In a system that will have an extended period (longer than 30 days) of non-use the EnviroServer may experience a lag in effluent quality that will correct itself within days of being returned to use and reintroduction of biological activity to the system. During these extended periods of non-use it is recommended to consult with the Authorized Service Provider. They may decide to deactivate certain components (discharge pumps, optional UV Light, and compressors) and to reactivate immediately upon returning the system to use.

NOTE: During extended periods of non-use DO NOT turn off the Alarm Control Panel power as this will deactivate any alarm conditions that could be sent through the optional Telemetry unit to the Authorized Service Provider.

Water Conservation

Conserving water will reduce hydraulic loading of the system and disposal field, however, the EnviroServer system is a biological process that needs wastewater to perform as designed. Although water conservation helps the efficiency of the EnviroServer system, extreme water conservation may adversely affect the performance of the system. The EnviroServer should not be used with Grey-water systems or systems that separate the wastewater from the facility.

- ◇ Turn off the water when it isn't needed (e.g. when washing food, dishes, hands; brushing teeth, etc.).
- ◇ Wipe dishes in the trash prior to washing.
- ◇ Take shorter showers. When bathing, don't fill the tub all the way.
- ◇ Use water-saving devices including faucets, shower heads, washing machines, dishwashers, and toilets.
- ◇ Only run washing machines and dishwashers with full loads.
- ◇ Spread out laundry chores throughout the week, rather than multiple loads in a day.
- ◇ Repair any leaking fixtures. A leaky toilet can waste as much as 2,000 gallons per day!!

Do Not Flush

The EnviroServer employs a natural biological process. As such, it is critical that certain items not be introduced to the system. Cleaning supplies should be used in a proper dilution as to not adversely affect the operation of the biological process. The items below constitute a representative example of items that should never be poured down a drain or flushed down a toilet. These items can overtax or destroy the natural biological digestion taking place within the system or clog pumps and pipes.

NOTE: These items are broad categories that are intended to serve as examples and are, by no means, all-inclusive.

- ◊ Toxic chemicals such as paints, varnishes, thinners, waste oils, photographic solutions, pesticides, herbicides, fertilizers, acids, and bleaches
- ◊ Gasoline in any form
- ◊ Fat, greases, and oils, including cooking refuse and large amounts of bath salts/oils
- ◊ Food by-products including coffee grounds, tea bags, fruit seeds, gum, eggshells, etc.
- ◊ Cigarette butts
- ◊ Kitty litter
- ◊ Paper products including non-septic-safe toilet paper, paper towels, facial tissues, disposable diapers, feminine hygiene products, flushable wipes, gauze bandages, etc.
- ◊ Condoms
- ◊ Dental floss, hair, pet hair, or lint (including from dryer and/or washing machine)
- ◊ Construction debris
- ◊ Cleaning supplies including disinfectants, detergents, rug cleaners, polishing wax, bleaches, etc.
- ◊ Septic additive products
- ◊ Prescription medicines including, but not limited to, antibiotics and chemotherapy
- ◊ Water softener back-flush

NOTE: Garbage disposals are not recommended with the Enviroserver system and should not be used with any septic system because they increase the organic loading to the system.

References

1. Shades, R.C., et al, "Waste Treatment Device and Method Employing the Same", Patent 5,958,252, Patent 6,048,452, Patent 6,139,744
2. NSF/ANSI Standard 40 Certification
3. "Design of Municipal Wastewater Treatment Plants Volume I", WEF Manual of Practice No. 8/ASCE Manual and Report on Engineering Practice No. 76 (1992).
4. "Design of Municipal Wastewater Treatment Plants Volume II", WEF Manual of Practice No. 8/ASCE Manual and Report on Engineering Practice No. 76 (1992).
5. "Operation of Municipal Wastewater Treatment Plants Volume I", Manual of Practice No. 11 Fifth Ed., WEF (1996).
6. "Operation of Municipal Wastewater Treatment Plants Volume II", Manual of Practice No. 11 Fifth Ed., WEF (1996).
7. "Operation of Municipal Wastewater Treatment Plants Volume III", Manual of Practice No. 11 Fifth Ed., WEF (1996).
8. "Nutrient Control", Manual of Practice No. FD-7, Water Pollution Control Federation, Washington, D.C. (1983).
9. "Clarifier Design", Manual of Practice FD-8, Water Pollution Control Federation, Washington, D.C. (1985).
10. "Wastewater Biology: The Microlife", A Special Publication, WEF, Alexandria, Virginia (1990).
11. "Water Reuse", Manual of Practice SM-3, Second Ed., Water Pollution Control Federation, Alexandria, Virginia (1989).
12. "Aeration", WEF Manual of Practice FD-13/ASCE Manuals and Reports on Engineering Practice No. 63 (1996).
13. "Wastewater Biology: The Life Process", A Special Publication, WEF, Alexandria, Virginia (1994).
14. "Treatment Process Digest", Water Environment Federation Digest Series, WEF, Alexandria, Virginia (1993).
15. "Wastewater Engineering: Treatment, Disposal, Reuse", Third Edition, Metcalf and Eddy, Inc. (1991).
16. Crites, R. and Tchobanoglous, G., "Small and Decentralized Wastewater Management Systems", McGraw-Hill (1998).

MATERIALS SUPPLIED BY MICROSEPTEC

The following items are supplied by MicroSepTec as part of the EnviroServer ES System:

Base Assembly

- ◇ Fiberglass tank assembly
- ◇ Three Access man-ways with lids
- ◇ Air Diffuser Assembly
- ◇ Recirculation Pump Assembly
- ◇ Effluent Filter
- ◇ Tank Plumbing
- ◇ Biomedia

Air Supply Assembly

- ◇ Air Compressor(s)
- ◇ Air Supply fittings
- ◇ Air Lines
- ◇ Compressor pressures switches

Control Configuration

- ◇ Alarm Control Panel
- ◇ Audible and visual alarm for high water level
- ◇ Audible and visual alarm for low air pressure
- ◇ Audible and visual alarm for optional UV light failure
- ◇ Timer controls for optional discharge pump & recirculation control
- ◇ Remote notification from separate control panel
- ◇ Floats (number depends on system configuration)
- ◇ Junction Box for recirculation control and wiring
- ◇ Electrical Fittings

Fragile components

These assemblies must be handled carefully to ensure that breakage does not occur.

- ◇ Air Compressor Assembly
- ◇ Controller
- ◇ Optional UV Assembly

Options

- ◇ Timed recirculation
- ◇ UV Disinfection
- ◇ Discharge pump controls
- ◇ Telemetry

Ordering Replacement Parts

Replacement parts are available from your local MicroSepTec distributor.

System layout

The EnviroServer ES utilizes various tank sizes, each with five separate compartments. The rated capacities for these tanks are listed in the table. A pre-installation site inspection will have determined the location and layout of the tank. The EnviroServer System will normally be installed in direct proximity to the main waste line exiting the structure.

ES Model	Treatment Capacity ¹ (Gallons Per Day)	Liquid Capacity (Gallons)	Dimensions (D X L)	Bottom of Inlet	Bottom of Outlet	Weight (Unloaded) (Pounds)
ES4.5	450	1,500	5' X 13' 6"	52"	46"	1,500
ES6	600	2,000	5' X 16' 4"	52"	46"	1,575
ES7.5	750	2,500	6' X 15'	64"	56"	1,650
ES12	1,200	3,650	6' X 21' 5"	64"	56"	2,000
ES25	2,500	7,550	8' X 24' 10"	88"	80"	3,000

Venting

Under normal circumstances, the system will vent back through the sewer venting system for the structure. However, when a pumping system (e.g. lift station) is used to move waste to the EnviroServer, additional venting should be installed. The vent should use 3" pipe from the middle riser and should include a minimum of 5' of pipe with fall toward the tank. The outlet should be capped with a carbon filter that should be properly maintained. Refer to installation instructions for carbon filter regarding placement, cover, etc.

Water Softeners

Check with the builder to ensure any water softening devices do NOT back flush into the wastewater treatment system. The brine from the discharge will have a significant negative impact on the chemical/biological process.

Power supply

Make sure the main power is switched off before attempting ANY electrical work on any portion of the system. Ensure sufficient measures are taken to prevent someone else from switching power on.

- ◇ Local Electrical Code must be followed
- ◇ Wire size should be based on best electrical practices and local code
- ◇ Alarm Control Panel power requirements

System	Breakers	Volts, HZ, AMPS
Gravity Discharge	Single from main panel	120VAC, 60HZ, 15 AMP
Simplex Pump Discharge	Two from main panel	1-120VAC, 60HZ, 15AMP 1-120VAC, 60HZ, 30AMP
Duplex Pump Discharge	Two from Main Panel	1-120VAC, 60HZ, 15 AMP 1-120V, 60 HZ, 40AMP

Site requirements

The EnviroServer ES can be used on various site in many conditions. Because of the compact size of the one tank, five chambers, total treatment the EnviroServer ES is suited for small lots, tight installations, steep slopes and many areas where it might be difficult to get a standard concrete system installed.

- ◊ The system requires 120V power to operate the compressors and the Alarm Control Panel. Steep sloping sites should have geotechnical engineering calculations to determine if soil retaining engineering is needed.
- ◊ The EnviroServer controller is sited above ground in a NEMA-4x-rated enclosure.
- ◊ The compressor is located on a secure surface within 50' of the tank, at a higher elevation than the tank.
- ◊ The cross-sectional space requirement for the tank in a standard (not traffic-rated) installation can be found in the minimum excavation sections
- ◊ Lids must be accessible at grade for service and scheduled maintenance (recommended 2-3 inches above final grade for help shed water and keep debris from tank when opening lids).

NOTE: The tanks do not ship with riser adapters or risers. These can be acquired locally. Risers should bring the lids to 2-3" above grade for service and accessibility. Bury depths greater than 4' will need to have all electrical and plumbing components extended/modified in the field. The EnviroServer system cannot be installed more than 6' below grade. However, any depth greater than 4' is not recommended, due to serviceability.

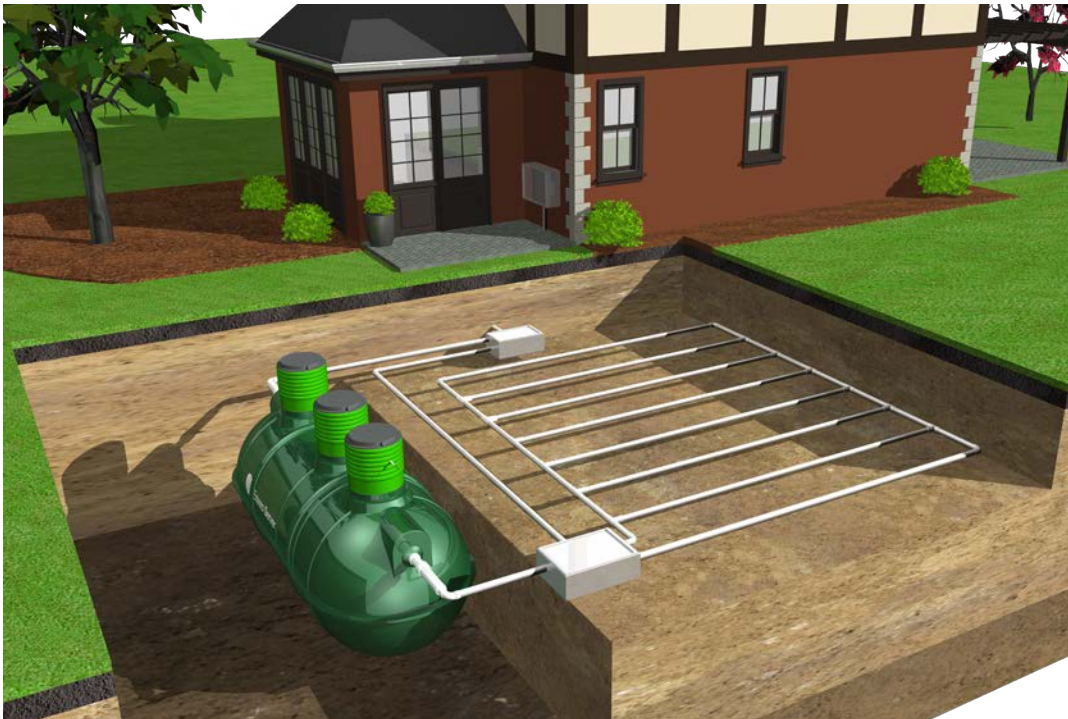

General

NOTE: This manual contains MicroSepTec's minimum recommendations only. Specifications of the project structural engineer supersede these recommendations. The EnviroServer System must be installed and serviced only by MicroSepTec authorized and trained representatives. Proper tools must be used in the installation process to ensure assembly to manufacturer's specifications and to prevent damage or injuries.

Installer responsibilities

- ◊ Include interconnections between the tank, compressor(s) and controller
- ◊ Electrical power supply
- ◊ Network Cable (for Telemetry Option only)
- ◊ Influent waste connection and effluent discharge.
- ◊ Shall assume sole and complete responsibility for the job site conditions during the course of construction, including the safety of all persons and property, and this requirement shall apply continuously and not be limited to normal working hours.
- ◊ Shall be responsible for all means and methods of construction and shall take all measures necessary to protect the structure during construction, including, but not limited to, shoring, bracing, and temporary excavations; and shall be in accordance with all state and federal safety requirements.
- ◊ Shall verify all dimensions, elevations, and site conditions before starting work and shall notify the architect and engineer immediately of any discrepancies.
- ◊ Shall determine the location of utility services in the area to be excavated prior to beginning excavation.
- ◊ All material and workmanship shall conform to the requirements of the latest edition of the local building code and shall comply with and be installed in accordance with all the requirements of all legally constituted public authorities having jurisdiction, including all county and local ordinances, and the safety orders of the state industrial accident commission (OSHA).

Tank Shipping, Unloading, Inspection and Storage

- ◊ Before the tank is unloaded or relocated on the job site, perform a visual inspection of the tank for damage.
- ◊ Before unloading the tank from the truck, contractor must make sure that all tools or other items that may damage the tank during unloading are removed from the trailer bed.
- ◊ Select a solid, level area to place the tank, and clear the area of rocks, trash and debris.
- ◊ Keep sharp objects from tanks, as they may puncture it.
- ◊ Be sure that all equipment used to lift the tank is rated to handle the load.
- ◊ Do not wrap chain or cable around the tank; use the lifting lugs only. Use a rope to guide the tank.
- ◊ Do not allow driver to release straps securing the tank to the truck until lifting equipment is secured to the tank's lifting lugs. Failure to do so could result in serious injury.
- ◊ **Do not remove tank by dragging or rolling off the carrier.**
- ◊ Off-loading of the tank must be done with heavy straps, a spreader bar and a backhoe, forklift, crane or excavator. To do this safely, more than one person is needed.

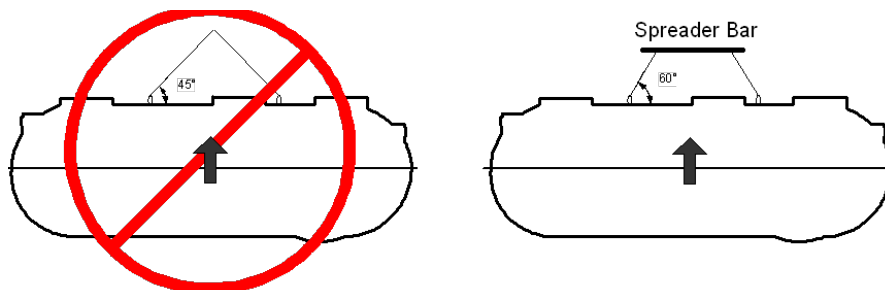

Use a spreader bar to prevent the lifting hooks from breaking free

INSTALLATION MANUAL

- ◇ Always chock the tank. The tank is heavy and has a large surface area; it will roll on sloped surfaces and could be blown about by the wind. Tie the tank down if high winds are expected. Movement of the tank could result in serious injury and/or damage to property.
- ◇ Always rotate the tank to prevent water from entering before it is backfilled. It is an underground storage tank and cannot hold water without soil surrounding and supporting it.

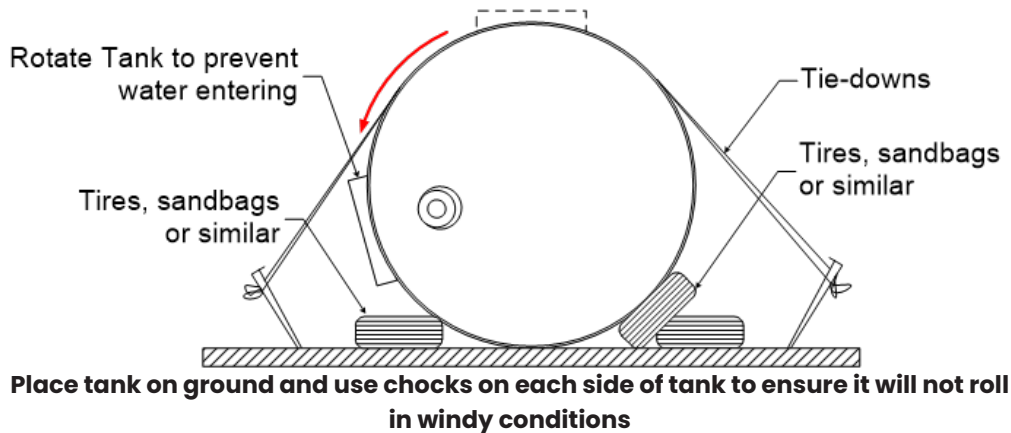

Backfill Specifications:

Note: Although the backfill material specifications are the same in traffic and non-traffic rated installations, the hole dimensions and amount of material used will differ. Refer to the Installation Drawings for more details.

- ◇ Use only approved backfill material. See approved backfill material section
- ◇ Do not mix approved material with sand or in-situ soil.
- ◇ Do not use in-situ soil as primary back fill material.
- ◇ Primary backfill material shall be free of ice and snow at the time of installation
- ◇ Approved backfill material shall be free of lumps, debris and frozen material at all times during the installation
- ◇ Typically all in-situ soil should be replaced with primary backfill material
- ◇ Material like soft limestone, sandstone, sea shells, or shale should not be used as backfill because they make break down over time

Note: Do not place tanks directly on concrete slabs, timbers, cradles, in material other than approved Primary backfill, or in-situ soil. Failure to do so will result in damage to the tank and void tank warranty

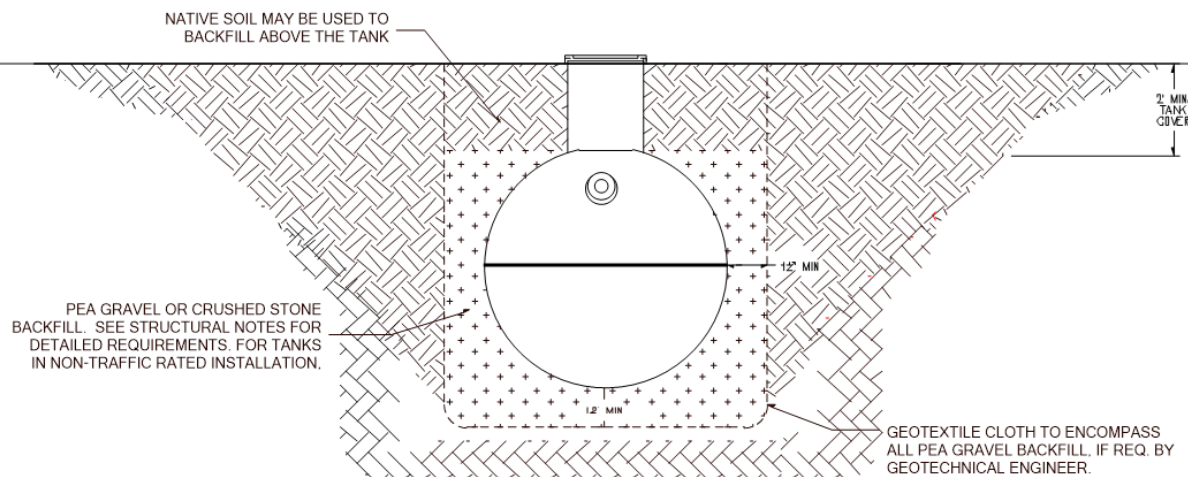

Approved primary backfill materials

MicroSepTec tanks must be installed using either pea gravel or crushed stone as backfill material. Use of backfill and bedding material other than that specified below without prior written approval will void tank warranty. Primary backfill material must extend a minimum of 12" around the tank including the pad the tank rest on.

Pea Gravel

- ◇ Naturally rounded aggregate with a particle size of not less than 1/8 inch and not greater than 3/4 inch.
- ◇ Gravel must be clean and free flowing, free from debris.
- ◇ Should conform to the specifications of ASTM C33, size number 6,67, or 7
- ◇ No more than 5% (by weight) of the backfill must pass through a # 8 Sieve

Crushed Stone

- ◇ Crushed stone or gravel with particle size not less than 1/8 inch and not greater than 1/2 inch.
- ◇ Crushed stone must be clean and free flowing, free from debris.
- ◇ Should conform to the specifications of ASTM C33, size number 7 or 8
- ◇ No more than 5% (by weight) of the backfill must pass through a # 8 Sieve

Secondary Backfill Specification

Secondary backfill can only be used at the above-specified distance from the tank walls. In **non-traffic** rated installations only, secondary backfill can be used above the tank.

- ◇ Coarse Sand or Gravel
- ◇ Coarse sand or gravel containing rocks no larger than 1 1/2 inches, and shall be clean and free from debris.
- ◇ During placement, this backfill material must be compacted to 95% relative compaction, as measured by ASTM D1557 procedures.

Select Native Backfill

- ◇ Clean native backfill containing rocks no larger than 1 1/2 inches can be used outside of the distances from the tank noted previously.
- ◇ During placement, this backfill material must be compacted to 95% relative compaction, as measured by ASTM D1557 procedures.

Excavation

Warning: Follow OSHA regulations for tank excavations. Collapse of excavation walls could result in serious injury.

- ◇ Take all precautions necessary to protect personnel working in or near a tank excavation.
- ◇ Locate and protect any utility installations near the excavation before opening the excavation.
- ◇ Secure the walls of the excavation.
- ◇ Prevent exposure of personnel to hazardous fumes from the excavation.
- ◇ Protect personnel from hazards associated with water accumulation in the excavation.
- ◇ Erect barricades, etc., to prevent unauthorized vehicle or pedestrian traffic.
- ◇ Inspect the excavation and surrounding area a minimum of once a day.
- ◇ Installation in water-saturated clay or in high water table can be completed with proper strapping and dead men.

Minimum Excavation Requirements

Minimum excavation requirements are for non-traffic rated burials in a typical installation. See complete installation drawings for dimensions needed for traffic rated installations.

ES Model	Treatment Capacity ¹ (Gallons Per Day)	Liquid Capacity (Gallons)	Minimum Excavation Length	Minimum Excavation Width	Minimum Excavation Depth	Primary Backfill Material (Approx)
ES4.5	450	1,500	15' 6"	7'	8'	17 YDS
ES6	600	2,000	18' 6"	7'	8'	20 YDS
ES7.5	750	2,500	17"	8'	9'	25 YDS
ES12	1,200	3,650	23' 5"	8'	9'	35 YDS
ES25	2,500	7,550	26' 10"	10'	11'	50 YDS

Burial Depth

Warning: In a non-traffic installation, ensure that the area above the tanks is not subject to traffic or other types of loads, which could cause tank damage and result in serious injury.

- ◇ The minimum depth of the excavation is normally determined by:
 - ◇ The presence or absence of groundwater
 - ◇ The presence or absence of traffic at the site, and 3) the relative location and depth of the main waste line from the structure. These dimensions are critical to the successful installation of a tank and may be regulated by code.
- ◇ All tanks must have a cover depth of at least 24 inches of backfill. Follow engineered installation drawings for installations requiring a traffic load.
- ◇ In a wet condition, an anchoring system must be present to offset buoyancy of the tank. Refer to engineered installation drawings for specifications.
- ◇ The maximum burial depth is 6 feet of cover over the top of the tank. However, at this depth the system will be very difficult to maintain and should therefore be avoided if possible.
- ◇ Asphalt and concrete pads must extend beyond the tank in all directions. Refer to engineered installation drawings in our specifications.
- ◇ Traffic loads from the top slab must not be transmitted to the attached risers. A minimum space of 3 inches must exist between the riser and the engineered slab.

Tank Spacing

If multiple tanks are to be installed in the same hole, allow for at least 30 inches between the tanks. This spacing must be increased as needed to accommodate dead men or anchor slabs or traffic load installations.

- ◇ The minimum spacing between the sidewall or endcap of the tank and the side of the excavation must be 18 inches.
- ◇ Always provide sufficient clearance to allow the dead men to be set outside of the tank shadow.
- ◇ Seek the advice of a local professional engineer or geologist if the native soil is extremely soft or inherently unstable. A reinforced concrete slab may be required under the tank as a foundation.

Filter Fabric Liner

- ◇ A filter fabric liner allows the passage of water but prevents the migration and mixing of native or secondary backfill soil and the primary backfill material. Geo textile (filter fabric liner) helps preserve the integrity of the backfill envelope that surrounds and supports the tank. The design engineer is responsible for determining whether a geotextile or an alternate filtering technique is appropriate for a specific installation.

- ◇ MicroSepTec recommends that a filter fabric liner always be used, particularly when the tank is installed in the following:
 - ◇ Areas with frequently changing groundwater conditions or areas subject to tidal fluctuations
 - ◇ Unstable soils (e.g. Sands)
 - ◇ Water conditions with silty soil.

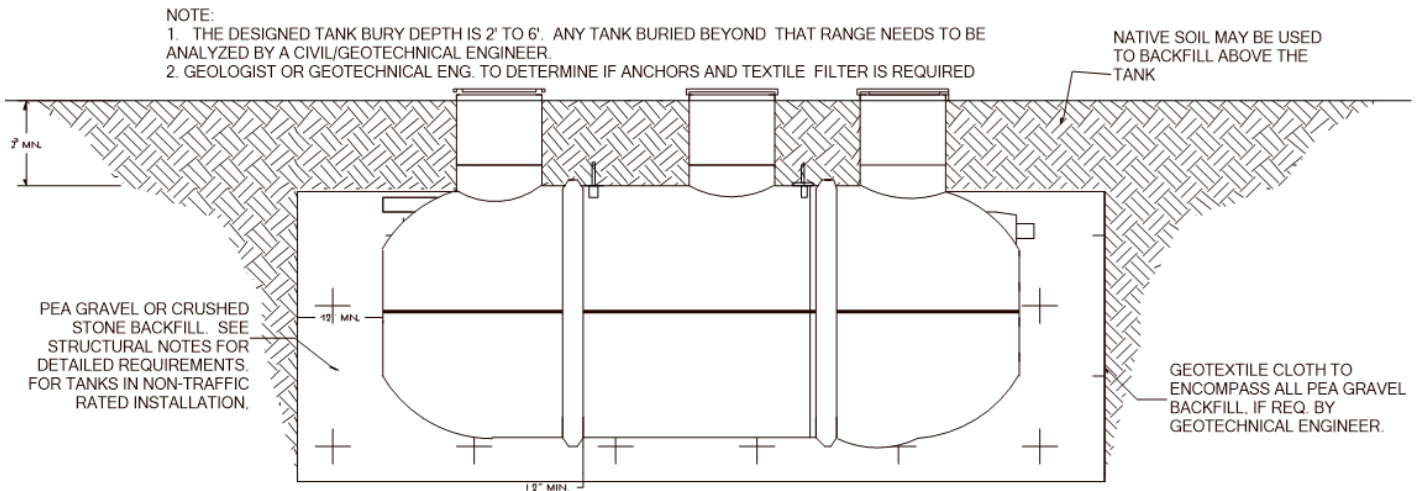

Tank Anchors

MicroSepTec recommends that every site be thoroughly evaluated for the potential of a rise in the local water table or of trapped water. Failure to anchor a tank when required may cause tank failure, or damage the tank or surrounding property. The design engineer is responsible for determining an appropriate anchoring system.

Deadmen

- ◇ Deadmen are typically reinforced concrete beams.
- ◇ The length of deadmen is typically equal to the length of the tank.
- ◇ The width and thickness of deadmen depend on the tank diameter, water-table height and burial depth. Refer to engineered Installation Drawings in Appendix I for specifications.
- ◇ Lay the deadmen in the excavation parallel to the tank and outside of the tank "shadow."
- ◇ Provide a separate anchor point for each hold-down strap and ensure the anchor points are located so that the straps can be placed over the ribs.

Tie Downs

- ◇ Use strapping material appropriate for soil conditions (consult with project geologist). Stainless Steel straps (or equivalent) preferred.
- ◇ Straps must be placed over ribs to avoid damaging the tank.

ANTI-FLOTATION COLLAR

- ◇ A steel-reinforced concrete collar can be installed in lieu of anchors and straps for anti-flotation
- ◇ Refer to engineered Installation Drawings in Appendix I for specifications

Backfilling

Use only approved backfill material and do not mix approved material with sand or other soil.

Do not use native soil as primary backfill material.

NOTE: It is critical that the tank is level when installed.

NOTE: Adequately ballast the tank (add liquid) in a wet hole or in a dry hole that may become wet (for example, from site runoff) until the installation is totally completed. Failure to do this may damage the tank or surrounding property.

Note: There are some steps of the watertight test performed during the backfilling procedure. Some component installation is easier prior to installation of risers and before completing the backfill procedure. Read the entire backfill and watertight testing procedures before starting the backfill process.

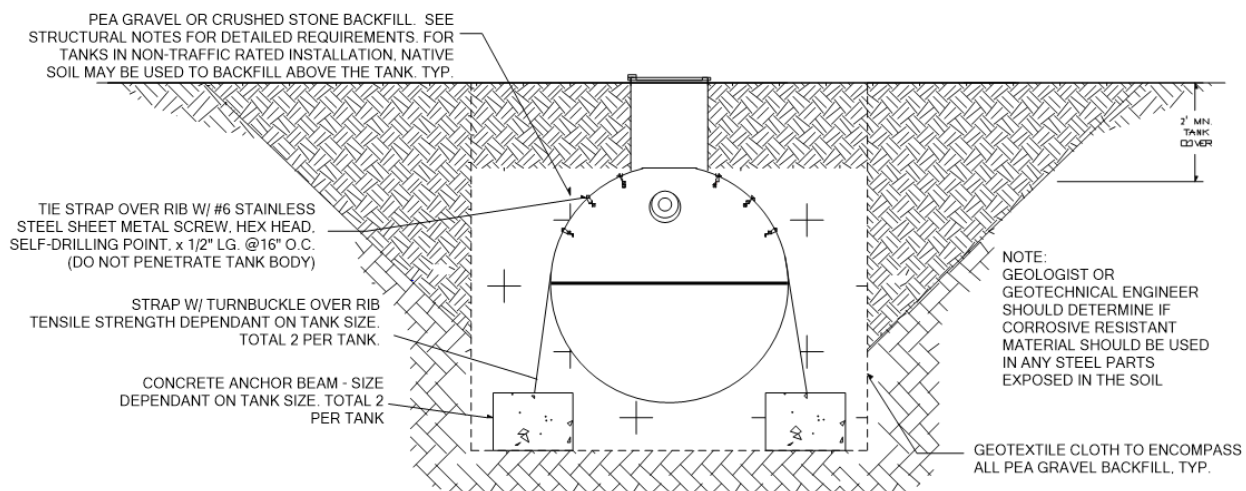

Dry-Hole Installation

- ◇ Locate the excavation site according to the plans
- ◇ Excavate the minimum excavation according to MicroSepTec policy. See minimum Excavation section.
- ◇ When preparing the excavation allow for anchoring systems or geotextile fabric if called for in the plans.
- ◇ If two or more tanks are used in the same excavation allow for a minimum 30" between tank sides or ends.
- ◇ If anchor slabs are required place them in the excavation now.
- ◇ Place 12" of primary backfill in bottom of the excavation and level.
- ◇ Install tank in the center of the excavation and level. Ensure to use proper lifting techniques with a spreader bar with the lifting lugs on the tank maintaining a 60° angle from the lifting lugs.
- ◇ There will be 8" difference in height between the inlet and outlet pipes when the tank is level.
 - ◇ Tolerance of +/- 1" is acceptable from inlet to outlet
- ◇ Establish lateral level by using a level across the top of the manways
- ◇ If the tank will use anchors or tie downs these should be installed at this time
- ◇ Once tank is in place, leveled and secured cover all manway holes, cap inlet and outlet pipes to ensure no debris enters the tank while backfilling
- ◇ Start filling primary backfill around the tank in 12" lifts. Ensuring compaction to 95% following ASTM D1557 procedures. use a nonmetal tamping rod long enough to reach beneath the tank to push material under the tank body and ends until solid resistance is felt. Being careful to not strike the tank with any tamping equipment as this may cause cracks in the tank.
- ◇ After the first 12" lift of primary backfill is around the tank place a hose in the middle compartment to start filling the second, third and fourth chamber with water.

Note: The second, third and fourth compartments are connected with underflow openings and should fill evenly.

Note: Ensure the covers are placed over the manways to ensure no debris enters the tank while filling tank with water.

Note: It is important to be filling the tank and backfilling at the same time to ensure the tank does not float out of the ground.

Note: Filling from the middle allows an inspection of the first and fourth baffle for water tightness.

- ◊ Continue backfilling and compacting in 12" lifts while checking to make sure that you are keeping pace with the water filling process in the middle three compartments.
- ◊ After the second 12" lift ensure tank is still level.
- ◊ Continue to check water levels in center compartments and make sure that no water is entering the first and fifth compartments while filling from the middle.
- ◊ Just before water has entered the fifth chamber turn off water and inspect the first and fifth compartments for signs of water leaking into these compartments from the center three compartments.

Note: If at any point during the process of filling water and backfilling you see water entering the first and fifth compartments stop the filling and backfilling procedure. Contact your local MicroSepTec distributor to have the baffle walls inspected and repaired for watertightness

- ◊ Once it has been determined that the baffle walls are watertight continue filling the tank from the center riser. Water will first enter the fifth chamber. Once water has filled the fifth chamber move the hose to the first manhole and fill the first compartment
- ◊ Continue the primary backfill and compaction lifts until you have reached the inlet and outlet levels of the tank or 80% of the way up the tank
- ◊ Continue filling with water until the water level is at the bottom of the outlet of the tank
- ◊ At this point you are ready to install riser adapters, risers, some internal components and conduct the watertight testing

Note: Local code will have precedence on the procedures and requirements for watertight testing. MicroSepTec performs air pressure tests at the factory, however MicroSepTec recommends hydrostatic test of all tanks. See watertight testing.

Wet-Hole Installation

- ◊ Locate the excavation site according to the plans
- ◊ Excavate the minimum excavation according to MicroSepTec policy. See minimum Excavation section.
- ◊ When preparing the excavation allow for anchoring systems or geotextile fabric if called for in the plans.
- ◊ If two or more tanks are used in the same excavation allow for a minimum 30" between tank sides or ends.
- ◊ Before performing the remainder of the installation, pump water from the excavation and continue pumping to maintain a minimum water level in the excavation during tank installation.
- ◊ Attempt to maintain the water level below the top of the bedding material until the tank can be fully backfilled and ballasted.
- ◊ If anchor slabs are required place them in the excavation now.
- ◊ Place 12" of Primary backfill in bottom of the excavation and level.
- ◊ Install tank in the center of the excavation and level. Ensure to use proper lifting techniques and the lifting lugs on the tank maintaining a 60° angle from the lifting lugs.
 - ◊ When setting and leveling tank, partially ballast the tank until it settles firmly in the prepared bed
 - ◊ The Ballast level in the tank should never exceed the water level in the hole by more than 12" until the backfill reaches the top of the tank
- ◊ There will be 8" difference in height between the inlet and outlet pipes when the tank is level.
 - ◊ Tolerance of +/- 1" is acceptable from inlet to outlet
- ◊ Establish lateral level by using a level across the top of the manways
- ◊ If the tank will use anchors or tie downs these should be installed at this time
- ◊ Once tank is in place, leveled and secured cover all manway holes, cap inlet and outlet pipes to ensure no debris enters the tank while backfilling
- ◊ Start filling primary backfill around the tank in 12" lifts. Ensuring compaction to 95% following ASTM D1557 procedures. Use a nonmetal tamping rod long enough to reach beneath the tank to push material under the tank body and ends until solid resistance is felt. Being careful to not strike the tank with any tamping equipment as this may cause cracks in the tank.
- ◊ After the first 12" lift of primary backfill is around the tank place a hose in the middle compartment to start filling the second, third and fourth chamber with water.

Note: The second, third and fourth compartments are connected with underflow openings and should fill evenly.

Note: Ensure the covers are placed over the manways to ensure no debris enters the tank while filling tank with water.

Note: It is important to be filling the tank and backfilling at the same time to ensure the tank does not float out of the ground.

Note: Filling from the middle allows an inspection of the first and fourth baffle for water tightness.

- ◇ Continue backfilling and compacting in 12" lifts while checking to make sure that you are keeping pace with the water filling process in the middle three compartments.
- ◇ After the second 12" lift ensure tank is still level.
- ◇ Continue to check water levels in center compartments and make sure that no water is entering the first and fifth compartments while filling from the middle.
- ◇ Just before water has entered the fifth chamber turn off water and inspect the first and fifth compartments for signs of water leaking into these compartments from the center three compartments.

Note: If at any point during the process of filling water and backfilling you see water entering the first and fifth compartments stop the filling and backfilling procedure. Contact your local MicroSepTec distributor to have the baffle walls inspected and repaired for watertightness

- ◇ Once it has been determined that the baffle walls are watertight continue filling the tank from the center riser. Water will first enter the fifth chamber. Once water has filled the fifth chamber move the hose to the first manhole and fill the first compartment.
- ◇ Continue the primary backfill and compaction lifts until you have reached the inlet and outlet levels of the tank or 80% of the way up the tank.
- ◇ Continue filling with water until the water level is at the bottom of the outlet of the tank.
- ◇ At this point you are ready to install riser adapters, risers, some internal components and conduct the watertight testing

Note: Local code will have precedence on the procedures and requirements for watertight testing. MicroSepTec performs air pressure tests at the factory, however MicroSepTec recommends hydrostatic test of all tanks. See watertight testing.

Watertight testing

Procedures for watertight testing

MicroSepTec performs an air pressure holding test of every tank prior to leaving the factory. A watertight test is recommended in the field to verify no unseen damage has occurred to the tank in delivery and to ensure certain chambers and tank are watertight.

Note: *Local code will have precedence on the amount of time required for watertight test procedures. The EnviroServer tank is designed specifically for underground storage and should be backfilled according to installation procedures to prevent tank from rupturing during watertight testing.*

Note: *Typically, watertight testing of fiberglass tanks does not require 24-hour hold time as fiberglass does not absorb water as a concrete tank would.*

Note: *Cure time of sealant depends on manufacturer of sealant. Ensure cure time is met prior to performing watertight testing.*

Note: MicroSepTec recommends a watertight test be performed after riser adapters and risers have been installed and prior to any component installation of the system. The watertight test should be performed to a level of no more than two inches above highest riser seam.

Note: If the watertight test will be performed with components installed in the EnviroServer system, use the following precautions

- ◇ The upper diffuser plumbing should be installed and ensure it is extended to above the water level for the watertight test level or connected to the air compressor fittings to ensure water and debris do not enter the diffusers. Water and debris inside the diffuser plumbing will be damaged, or impact the performance and longevity of the membrane diffusers.
- ◇ Water should not enter airlines to prevent damage to other components (e.g. pressure switches, needle valve, solenoid valve, diffusers, etc.).

Note: Follow MicroSepTec procedures for tank installation, using only approved primary and secondary backfill specifications

Note: Watertight test may start during the backfill procedure to ballast tank and to test that the Aeration Chambers and Final Clarifier do not have leaks between the Primary Clarifier and Effluent Storage compartments. Leaks between the Primary Clarifier and the First Aeration Chamber or the Final Clarifier and Effluent Storage are not typical.

- ◇ During the backfilling and watertight testing, ensure the lids cover the manways to prevent debris from entering the tank

All local, state and OSHA safety and excavation regulations must be followed during the tank installation procedure

- ◇ Once the first lift of primary backfill has been completed and tank level has been verified, start filling the middle three compartments from the middle riser
 - ◇ Water underflows between the first aeration chamber, second aeration chamber and final clarifier
- ◇ The water level inside the tank and backfill material outside the tank should always be at about the same elevation. If the water level is higher than the gravel, the tank could be damaged by the hydrostatic pressure, and if the gravel level is higher than the water level, the tank may lift
- ◇ Continue checking the primary clarifier and effluent storage compartment to ensure no water is leaking into the compartments from the middle three compartments
 - ◇ If water leaks into effluent storage chamber, contact your MicroSepTec distributor or MicroSepTec to arrange for the leak to be corrected
- ◇ Continue the backfill procedure and checking water in the primary clarifier and effluent storage for leaks until just prior to the water reaching the level of the effluent filter outlet
- ◇ If no water has entered the primary clarifier or the effluent chamber it is safe to continue the backfilling and watertight test procedure
- ◇ Seal off the influent and effluent piping with watertight caps or plugs
 - ◇ Install and seal risers (and, if applicable, riser adapters) to the tank according to manufacturer's recommendations and allow seal to cure
 - ◇ MicroSepTec prefers monolithic risers to 2"-3" above finished grade
 - ◇ If jointed risers will be used, ensure they are installed according to manufacturer's recommendations and allow seal to cure
- ◇ Continue filling the tank to no more than 2" above highest seam
- ◇ Let the water stand for at least one hour and allow water temperature to stabilize. Local code may require longer hold times
- ◇ If the water drops, check to see that the inlet and outlet plugs aren't leaking. Check to ensure no leaks around any of the joints of the riser or riser adapter. Repair any loose fittings or leaking joints and return water back to a level of 2" above the highest seam
- ◇ If the water level does not stabilize, contact the local MicroSepTec distributor

Cold Weather

The EnviroServer ES introduces warm air through the compressors, this warm air not only supplies process air to the EnviroServer ES series, but also helps raise the temperature in the EnviroServer ES Series to help in the biological process and denitrification.

Note: State and local code will determine if cold weather applications will be needed

Note: State and local code should be followed if tank insulation is required

If the temperature of the wastewater in the EnviroServer drops below the temperatures listed in the influent characteristics appropriate steps should be taken to increase the temperature of the wastewater in the EnviroServer ES Series. Consult with MicroSepTec on possible solutions to raise wastewater temperature which may include the addition of warm air or insulation of the EnviroServer.

Tank Insulation

Note: Local and state code will determine if tank insulation is required

INSTALLATION MANUAL

Note: Tank insulation should conform to state, local code, and be rated for direct burial

Spray Foam

Note: Ensure no spray foam insulation enters the EnviroServer in the process of insulating the tank

- ◇ Insulate the bottom $\frac{2}{3}$ (to the bottom of the outlet) of the EnviroServer ES Series tank with appropriate direct burial spray foam prior setting the tank in the excavation
- ◇ Install tank and backfill in accordance with tank installation procedures in the INSTALLATION MANUAL
- ◇ Insulate the top of the tank once riser adapters and risers have been installed, watertight testing has been performed (if applicable by state and local code), and all connections have been made through the risers

Sheet Foam

- ◇ Use 2" thick sheet insulation
- ◇ Install tank, riser adapters, risers, connections, conduct watertight testing (if applicable by state and local code), and backfilled according to directions in the "INSTALLATION MANUAL" to within 8-12" from finished grade and smooth backfill
- ◇ Place sheet foam insulation over the excavation to extend 18"-24" inches beyond the tank
- ◇ Ensure insulation is sealed (taped) together
- ◇ Complete backfilling over the sheet foam, being careful not to damage sheet foam insulation

Internal Component Installation

1. Inlet and Outlet Connections

- ◊ Connect the 4" waste line source to the 4" inlet on the EnviroServer.
- ◊ If the system includes the optional mechanical recirculation pump, install a 4" clean-out (included) at least 24" in front of the inlet. Install the 4" x 1½" reducing tee (included) in the vertical clean-out pipe so that the 1½" inlet is a minimum of 12" above the inlet pipe. A recirculation pipe will be plumbed from the third riser to the 1½" inlet later.
- ◊ If the system is to be installed using the gravity outlet, install a 4" effluent line to the tank outlet.
- ◊ If the effluent is to be pumped to the dispersal system, cap the tank outlet. A separate pipe will be run later at the desired outlet height.

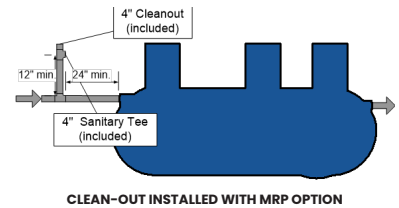

Components in Second Riser

2. Lower Air Diffuser Assembly and Installation

The Air Diffuser Assembly is installed in the second and third compartments of the tank, which are accessed through the middle riser. The Air Diffuser assembly delivers air from the compressor(s) to promote aerobic digestion.

The assembly consists of the following sub-assembly parts, as indicated in Photo 1, and completed assembly in Illustration 1:

1. Diffusers (2 pieces)
 2. Upper Pipe and Support Sections (2 pieces), including:
 - a. Airline quick-connect swivel elbows
 - b. ¾" CLICTM pipe hangers
 3. Pipe Hanger,
 - a. Including two ¾" CLICTM clamps with ¼" threaded stainless steel rod (1 piece)
 4. Adjustable Upper Pipe Sections (incl. elbows) (2 pieces)
 5. Middle Pipe Sections (incl. couplings) (2 pieces)
 6. Lower Pipe Sections (incl. male thread elbows) (2 pieces)
- ◊ Screw the diffusers (1) on to each of the lower pipe sections (6).

NOTE: Use Teflon tape on the threads.

- ◊ Glue the middle pipe section (5) to the lower pipe section (6).

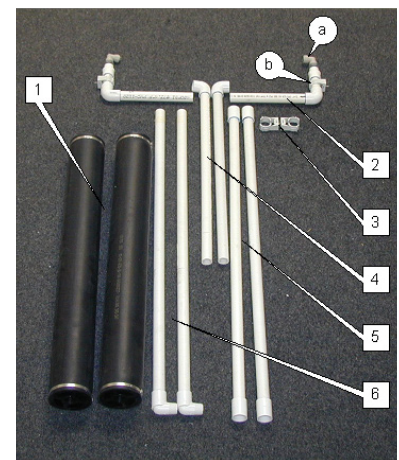

PHOTO 1
AIR DIFFUSER PARTS

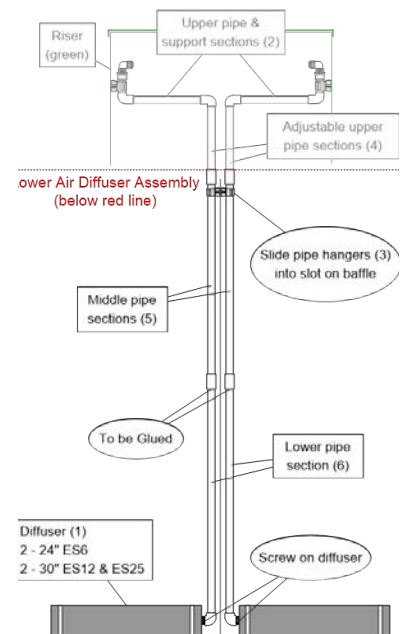

ILLUSTRATION 1
AIR DIFFUSER ASSEMBLY

- ◇ Set the pipe hanger in the slot (Photo 2) on the baffle located in the second man-way

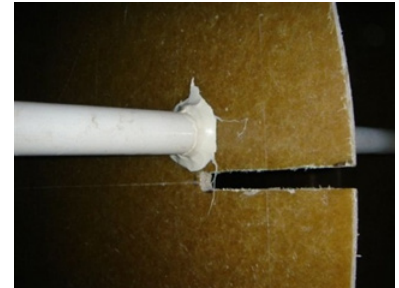

PHOTO 2
PIPE HANGER MOUNTING SLOT

- ◇ Adjust the pipe hanger (Photo 3) so that it is loose enough to allow both diffusers to be pulled upward for easy removal during servicing.

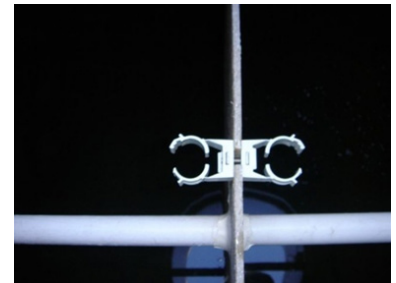

PHOTO 3
PIPE HANGER MOUNTED LOOSELY

- ◇ Install each lower diffuser assembly into the second and third compartment through the second man-way. Align the diffusers so they are parallel to the tank (180° in opposing directions and set in the alignment guide in the bottom of the tank) (Photo 4).

NOTE: Be careful to keep the diffusers away from the man-ways when inserting, as the fiberglass may tear the rubber diaphragms.

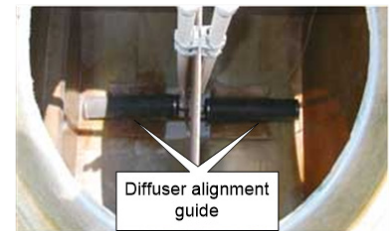

PHOTO 4
LOWER DIFFUSER ASSEMBLY MOUNTED ON PIPE HANGERS WITH DIFFUSERS IN ALIGNMENT GUIDE

- ◇ Attach the assembly to the pipe hanger by pressing each pipe into the clamp. The clamp will automatically close around pipe and lock (Photo 5).



PHOTO 5
PRESS PIPE INTO CLAMP

3. Biomedia Installation

The Biomedia serves as a surface for the aerobic bacteria to live and grow and keep the water constantly agitated.

- ◇ Pour the biomedia evenly between the two aerobic chambers containing the diffusers (middle riser). There should be an equal volume of Biomedia on each side of the baffle wall. (Photo 6).



PHOTO 6
BIOMEDIA POURED INTO THE TWO AEROBIC CHAMBERS

4. Tubing Installation

- ◇ Run two (2) 1/4" tubing lines through the sleeve (Photo 7) located between the second and third man-way.

NOTE: These airlines will be used later to connect to the INCOMING AIR SUPPLY (Step 6) to the Airlift Pump (Step 15), Recirculation Control Valve and Pressure Switch(s) (Step 16).

NOTE: The recirculation control valve (needle valve or solenoid valve) will be installed in the third riser, so that the service provider can make adjustments to the recirculation rate at the airlift pump.

5. Install Riser Adapter, Risers and Riser Extensions on middle man-way

The EnviroServer ES Series is not shipped with riser adapters or risers, these should be obtained locally. Installation of riser adapters and risers should follow procedures from the product manufacturer.

The EnviroServer will accommodate most riser adapters. The third man-way is capable of accepting a 30" diameter riser adapter and riser to ease the installation process and also make components more accessible for future service work.

When drilling through the EnviroServer Tank for the to install riser adapters use caution. DO NOT use dull, damaged, or concrete drill bits as this could cause damage to the tank.

Installation of risers should be performed after work is done in the man-way. Installing the risers early may make installation of components difficult.

- ◇ Use sandpaper to rough the surface of the fiberglass and clean prior to using caulking to bond between tank and riser adapter, between riser adapter and riser (acetone cleaner is most effective). Use sealant that will bond between the two surfaces and ensure watertight seal.

6. RISER ADAPTER INSTALLATION

- ◇ Install according manufacturers recommendations.
- ◇ If using screws to join the Riser Adapter to the tank use no more than eight(8) #12 1 3/4" stainless steel screws

Riser Installation

- ◇ Install according manufacturers recommendations



PHOTO 7
BIOMEDIA POURED INTO THE TWO AEROBIC CHAMBERS

7. Incoming Airline Installation

Single compressor Air Supply Kit

The single compressor Air Supply Kit (photo 8) includes a 1" bulkhead fitting, a quick-connect Air Supply Cross, a reducer elbow for connecting the compressor, and 8 feet of ½" airline. The bulkhead and cross will be installed in the center riser to distribute air from the air compressor to the air diffusers, airlift recirculation pump (if applicable) and pressure switch. Ideally, this step will be completed once final grade is known and the risers are cut to the appropriate height.

NOTE: The Air Supply cross should be installed as high in the riser as the supply pipes will allow, so it is accessible for servicing.

Double compressor Air Supply Kit

The double compressor Air Supply Kit (Photo 9) includes two 1" bulkhead fittings, two quick-connect Air Supply Tees, two reducer elbows for connecting the compressors, and 8' of ½" airline. The bulkheads and tees will be installed in the center riser to distribute air from the air compressors to the air diffusers, airlift recirculation pump (if applicable) and pressure switches.

NOTE: The Air Supply tees should be installed as high in the riser as the supply pipes will allow, so they are accessible for servicing.

- ◊ Drill one (single compressor models) or two (double compressor models) 2" hole(s) in the center riser for mounting the bulkhead fittings and Air Supply Cross or Tees (Photo 10). When cutting two holes, take care in spacing them so that the Air Supply Tees, and all tubing to be attached to the tees, do not obstruct each other.
- ◊ Install bulkhead with the short length of pipe inside the riser.
- ◊ Tighten the bulkhead fittings and glue the cross or tees to each bulkhead fitting

NOTE: When installing bulkhead fittings, 1) always install with rubber gasket inside the tank, as salts in the soil may break down the seal over time; and, 2) never turn the side with the O-ring, as it will force the O-ring out of shape so that the fitting won't seal.

8. Upper Air Diffuser Assembly and Installation

The following will complete the installation of the Air Diffuser Assembly started previously. Ideally, this step will be completed once final grade is known and the risers are cut to the appropriate height.

- ◊ Ensure that the lower diffuser assembly is locked in the slot in the baffle (refer LOWER AIR DIFFUSER ASSEMBLY Step 2).
- ◊ Assemble the Adjustable Upper Pipe Sections and Upper Pipe and Support Sections without gluing the joints.

- ◊ Align the Upper Pipe and Support Sections over the diffusers, as indicated in the adjacent illustration.

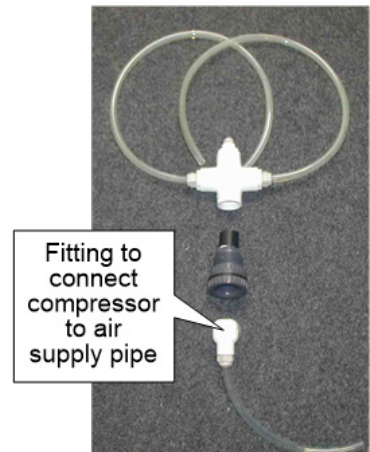

PHOTO 8
SINGLE COMPRESSOR AIR SUPPLY ASSEMBLY

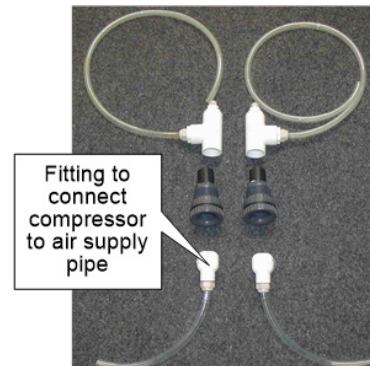
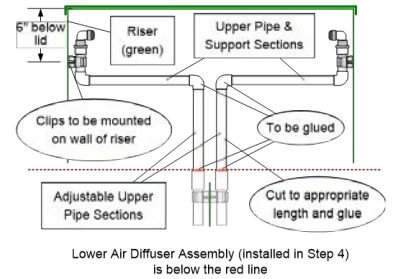

PHOTO 9
DOUBLE COMPRESSOR AIR SUPPLY ASSEMBLY



PHOTO 10
CUTTING HOLE FOR BULKHEAD FITTING

- ◇ Ensure that the Adjustable Upper Pipe Section is cut so that the vertical and horizontal lengths of the completed assembly will allow it to be mounted to the man-way wall with the pipe clamps about 6" below the top of the riser, as indicated in the adjacent illustration (above).
- ◇ Glue the assembly.



Lower Air Diffuser Assembly (installed in Step 4) is below the red line

PHOTO 11

UPPER AIR DIFFUSER ASSEMBLY AND INSTALLATION

- ◇ Mark the locations for the pipe clamps on the side of the man-way.
- ◇ Gently bend the pipe out of the way and secure the pipe clamps to the risers with the stainless steel screws.

- ◇ Attach the upper assembly clamps by pressing the pipe against the clamp. The clamp will automatically close around the pipe and lock.

NOTE: If top of the tank is buried more than 24", additional pipe may be needed to extend the vertical length of the adjustable upper pipe sections. Do not install risers more than 4 feet tall, as serviceability will be a problem.

9. Airline Connections

- ◇ Connect a short length of 1/2" tubing between one outlet of the Air Supply Tee (or Cross) (Photo 14 and 15) and the 1/2" quick-connect airline fitting on the diffuser in the second chamber (first aeration chamber).

NOTE: When inserting tubing into the quick-connect fittings, the tubing will stop when it reaches the internal O-ring; push past the O-ring (about another 1/4") to seal the connection.

NOTE: Use as little 1/2" tubing as possible: no more than 3 feet to minimize friction loss and back pressure on the compressor.

- ◇ Connect the 1/2" tubing on the other Air Supply Tee (or Cross) by cutting the tubing about 2" from the Air Supply Tee



PHOTO 12

CONNECT PIPE CLAMP TO RISER WITH 1" SCREW



PHOTO 13

PRESS PIPE INTO CLAMP

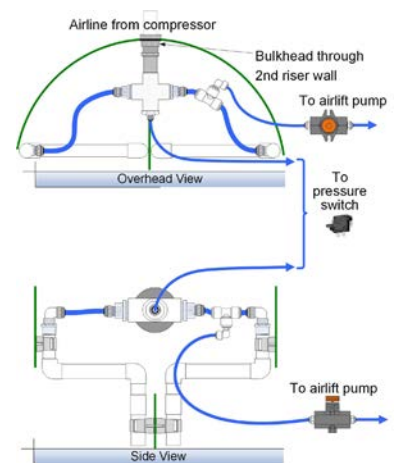

PHOTO 14

SINGLE COMPRESSOR AIRLINE PLUMBING

INSTALLATION MANUAL

- ◇ Install the 1/2" push connect tee with the 1/4" swivel tee.
 - ◇ Connect the 1/2" tubing to the tee with the 1/4" swivel and to the 1/2" quick-connect airline fitting on the diffuser in the third chamber (second aeration chamber).
 - ◇ Connect 1/4" airlines (installed in Step 4)
 - ◇ One 1/4" airline connects to the 1/4" quick connect fitting on the swivel tee. (This will connect to the recirculation control valve in Step 12 and to the Airlift pump installed in Step 15)
 - ◇ One 1/4" airline connects to the 1/4" quick connect fitting on Air Supply Tee (or Cross) this will connect to the pressure switch(s) installed in step 16

NOTE: If the external plumbing to the compressors is not ready to be installed, insert a capped pipe into the exterior of the bulkhead to prevent debris from entering the air distribution system.

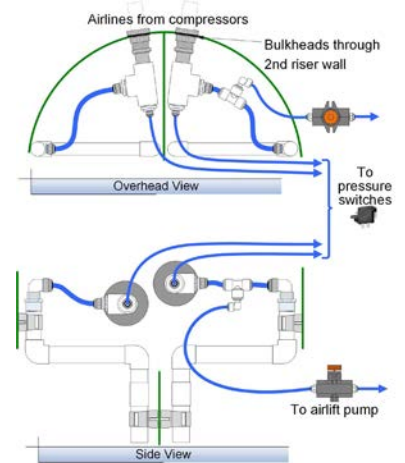

PHOTO 15
DOUBLE COMPRESSOR AIRLINE PLUMBING

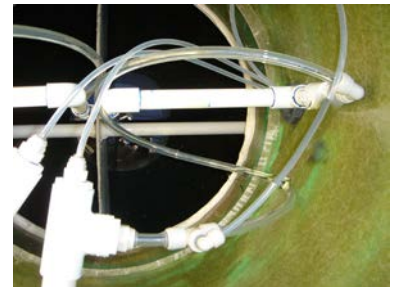

PHOTO 16
AIRLINE WITH SWIVEL TEE



PHOTO 17
1/4" TUBING TO PRESSURE SWITCH FROM AIR SUPPLY

Components in Third Riser

NOTE: Take a few moments to map out how the man-way will look once everything has been installed to ensure all components will be accessible for servicing. Keep in mind the service provider will need to be able to remove the effluent filter, recirculation pump, UV lamp and effluent pump(s), as well as access the junction box and disconnect float cables, and airlines to the pressure switches.

10. Lower UV Disinfection Assembly Installation (optional)

MicroSepTec typically does not supply the UV Disinfection units, as these vary widely by region. However, the EnviroServer can accommodate the installation of UV Disinfection units internally to the tank. An example of internal installation is provided for reference. Follow manufactures installation procedures for a the UV disinfection unit.

The UV assembly (Photo 18) is installed inside the fifth (final) compartment and accessed through the third riser. Treated water passes through the Assembly so that any remaining pathogens are destroyed.

The UV Assembly consists of the Lower UV Assembly, Extension Pipe, Quartz Sleeve, PVC Handle, Electrical Sub-Assembly and the Lamp. The Electrical Sub-Assembly is pre-wired and factory-sealed, so it will not need to be opened during installation. A cable for power and alarms is pre-wired through the side of the junction box, and a cable to connect the lamp is pre-wired through the bottom of the box. The Lamp ships inside the Handle, while the Sleeve ships inside the Lower Assembly. There are also two 4" ABS couplings in the box, but they are not typically used with the EnviroServer.

At this point in the installation process, only the Lower Assembly will be installed.

- ◊ Remove the protective plugs from the three openings of the Lower Assembly
- ◊ Thread the PVC Handle onto the male thread at the top of the Quartz Sleeve

NOTE: Use Teflon tape on the threaded connection.

- ◊ Remove the Quartz Sleeve and store in a safe place until the rest of the UV Disinfection Assembly is installed in step 11 (UPPER UV DISINFECTION ASSEMBLY AND INSTALLATION)(Photo 19)
- ◊ Glue the Lower Assembly into the 4" coupling, directly opposite the effluent filter. Use a level to ensure the assembly is mounted vertically (Photo 20)

NOTE: Use ABS Glue.

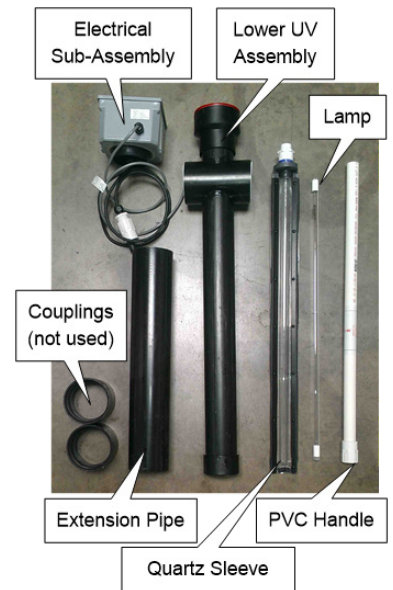

PHOTO 18
UV ASSEMBLY COMPONENTS



PHOTO 19
QUARTZ SLEEVE REMOVED

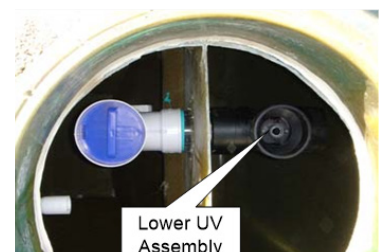

PHOTO 20
LOWER UV ASSEMBLY MOUNTED

11. Riser Adapter, Risers and Riser Extensions

The EnviroServer ES Series is not shipped with riser adapters or risers, these should be obtained locally. Installation of riser adapters and risers should follow procedures from the manufacture of the product.

The EnviroServer will accommodate most riser adapters. The third man-way is capable of accepting a 30" diameter riser adapter and riser. In some instances a 30" riser will ease the installation process and also make components more accessible for future service work.

Installation of risers should be performed as work is done in the manway. Installing the risers early may increase difficulty during the installation of components.

- ◇ Use sandpaper to rough the surface of the fiberglass and clean prior to using caulking to bond between tank and riser adapter, between riser adapter and riser (acetone cleaner is most effective). Use sealant that will bond between the two surfaces and ensure watertight seal.

RISER ADAPTER INSTALLATION

- ◇ Install according manufacturers recommendations.
- ◇ If using screws to join the riser adapter to the tank use no more than eight(8) #12 1 3/4" stainless steel screws

Riser Installation

- ◇ Install according manufacturers recommendations

12. Upper UV Disinfection Assembly and Installation (optional)

The Upper UV assembly will be mounted to the Lower Assembly, installed earlier (Step 9). Ideally, this step will be completed once final grade is known and the risers are cut to the appropriate height.

- ◇ The Extension Pipe may need to be cut or extended, depending on final grade. There must be about 6-8" clearance between the top of the riser and the top of the Extension Pipe so that the Electrical Sub-Assembly can mount to the Extension Pipe
- ◇ Glue the Extension Pipe into the Lower UV Assembly (ABS cross) (Photo 21)

NOTE: Use ABS Glue.

- ◇ Carefully insert the Quartz Sleeve and PVC Handle (removed in Step 9) through the Extension Pipe and into the Lower Assembly. The black, rubber-lined, metal edges of the Quartz Sleeve should be 90 degrees offset to the 4" cross
- ◇ Make sure the holes at the top of the Quartz Sleeve align with the pins in the housing and the tube is seated appropriately (Photo 22)
- ◇ The PVC handle may need to be cut so that a service technician can grab the handle inside the Extension Pipe, but low enough that the Electrical Sub-Assembly can mount on top of the Extension Pipe
- ◇ The Lamp Cord connects inside the Electrical Sub-Assembly and has a 4-prong plug at the other end
- ◇ Apply dielectric grease (included) to the white base of the Lamp to seal the boot connection



PHOTO 21

EXTENSION TUBE INSTALLED

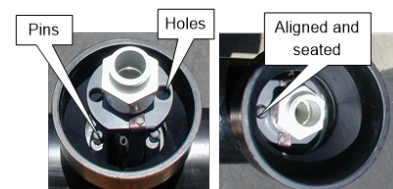

PHOTO 22

ALIGN PINS TO HOLES IN QUARTZ SLEEVE

- ◇ Carefully connect the 4-prong plug to the UV Lamp (Photo 23)

WARNING: Never touch glass bulb with bare hands.

NOTE: Do not force the connection.

- ◇ Make sure the heat-shrunk boot extends over the Lamp and the grease forms a seal against moisture (Photo 23)
- ◇ Gently push the UV Lamp through the PVC Handle and down the Quartz Sleeve.

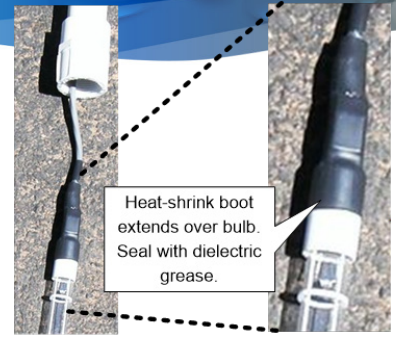

PHOTO 23
CONNECTION TO UV LAMP

WARNING: MAKE SURE THAT THE BULB IS SEATED AT THE BOTTOM OF THE SLEEVE. THE 4-PRONG PLUG WILL BE INSIDE THE QUARTZ SLEEVE IF SEATED CORRECTLY. FAILURE TO SEAT THE BULB IN THE SLEEVE WILL RESULT IN HEAT DAMAGE AND POSSIBLY FIRE.

- ◇ Glue the watertight fitting assembly onto the end of the PVC Handle (Photo 25)
- ◇ Mount the Electrical Sub-Assembly on to the top of the Extension Pipe, taking care to prevent the lamp cord from being pinched by the box (Photo 26)

NOTE: Do not glue Electrical Sub-Assembly to Pipe.
Once complete, the UV Disinfection Assembly should look like the drawing (Photo 27)

The manufacturer's installation instructions can be obtained from your local distributor.

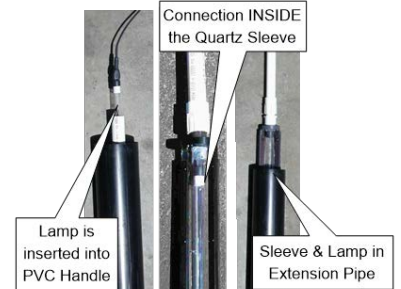

PHOTO 24
LAMP INSERTED THROUGH PVC HANDLE INTO QUARTZ SLEEVE, THEN INTO EXTENSION PIPE



PHOTO 25
WATERTIGHT FITTING INSTALLED ON HANDLE

To remove UV light:

1. Turn off power to the UV unit
2. Twist the J-box loose and let it hang on the side of the tube.
3. Gently pull the PVC Handle up to extract the Quartz Sleeve.
4. Disconnect the booted connector from the UV lamp.
5. Extract the UV Lamp from the Quartz Sleeve.



PHOTO 26
UV JUNCTION BOX ON TOP OF EXTENSION TUBE

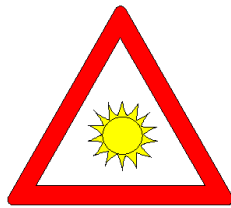

WARNING.
EXTREME UV RADIATION.
DO NOT LOOK AT UV LIGHT
WHEN IT

WARNING:
Never touch glass bulb with bare hands!
Never look at UV light when on!

13. Electrical Penetration and Junction Box Installation

The ES Series comes with a standard junction box assembly (photo 28) for electrical connections of the high-level float, pressure switch(es), recirculation valve, and optional UV Assembly.

MicroSepTec also supplies a Pump Control Upgrade Kit (Photo 29) to allow for the installation of discharge pumps and additional floats in the junction box. Refer to the Technical Bulletin for the Pump Control Upgrade Kit for further information.

Junction Box Penetrations

There will be several holes drilled into the junction box, depending on configuration and preference.

- ◊ Determine the location of the electrical penetrations in the junction box for the 2" male adapter and snubbers for the lines coming from the tank, and the 1" male adapter for the conduit(s) to the controller. See the adjacent picture for recommended location of penetrations
- ◊ Use a 2 3/8" hole saw to cut holes in the junction box for the 2" male adapters (Photo 29)
- ◊ Use a 1 3/8" hole saw to cut hole for each 1" conduit to the controller (Photo30). If installing multiple conduits to the controller, leave at least 1 1/2" between the outside edges of each hole
- ◊ Insert 2" male adapter into the holes drilled in the junction box, and mount with the supplied lock-nuts and seals. If applicable, insert individual cord seals into the 3/4" holes and mount with the supplied lock-nuts and seals
- ◊ Insert 1" male adapter into each hole for conduits back to the controller and mount with the supplied lock-nuts and seals (Photo 31)

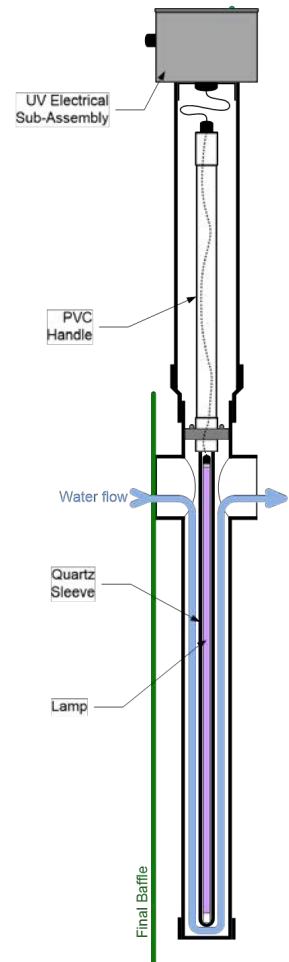

PHOTO 27
COMPLETE UV ASSEMBLY



PHOTO 28
JUNCTION BOX ASSEMBLY KIT



PHOTO 29
PUMP KIT UPGRADE

INTERNAL MOUNT

THROUGH-RISER PENETRATION

- ◊ Use the holes in the junction box (see "JUNCTION BOX PENETRATIONS" above) as a template to determine the location of the penetrations in the riser
- ◊ Use a 1 3/4" hole saw to cut holes in the third riser for installation of the 1" conduit(s).
- ◊ Insert 1" grommet(s) into the hole(s)
- ◊ Insert 1" electrical conduit(s) through the grommet(s) so that there is about 2" of pipe inside the riser
- ◊ Glue the Junction Box to the 1" conduit(s) (Photo 33)

RUN CABLES AND AIRLINES

- ◊ Insert the 6-Hole Cord Seal into the 2" electrical male adapter installed above ("JUNCTION BOX PENETRATIONS")
- ◊ Feed the cables and airlines from the tank through the 6-Hole Cord Seal(s) (and/or individual cord seals, if used) to the junction box. Use the supplied plugs for any unused holes
- ◊ Tighten the nut on the Cord Seal with a 7/16" wrench to form a water/gas-tight seal around the cables and airlines, and, if used, the individual cord seals.
- ◊ Run wiring from the Alarm Control Panel to the junction box
- ◊ Make electrical and air connections inside the junction box, using the watertight connectors
- ◊ Insert desiccant in the completed box and mount the lid. Do not over-tighten screws when mounting the lid



PHOTO 29
2" ELECTRICAL PENETRATION



PHOTO 31
1" ELECTRICAL PENETRATION

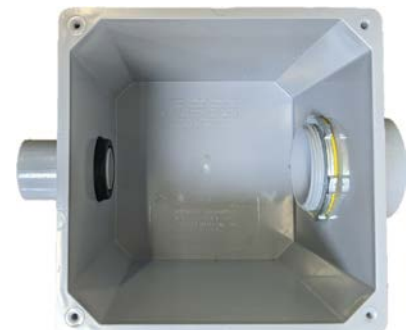

PHOTO 32
READY FOR INSTALLATION

EXTERNAL MOUNT

THROUGH-RISER PENETRATION

- ◇ Use the holes in the junction box (see "JUNCTION BOX PENETRATIONS" above) as a template to determine the location of the penetrations in the riser
- ◇ Use a 3" hole saw to cut a hole in the third riser for installation of the 2" conduit.
- ◇ Install 2" grommet in the riser
- ◇ Glue the two 2" electrical couplings to the supplied 2" conduits (one coupling per conduit). If the junction box needs to be more than about 10" from the riser, the installer will need to supply a longer pipe. The cable and airline lengths will limit how far outside the riser the junction box can be mounted
- ◇ Slide the 2" conduits through the grommet so that the 2" couplings are against the grommet, inside the riser
- ◇ Glue the two 2" pieces of conduit to the 2" male adapters installed in the junction box above (see "JUNCTION BOX PENETRATIONS") (Photo 34)
- ◇ Glue 1" Conduit(s) to the 1" male adapter(s) installed in the junction box above (see "JUNCTION BOX PENETRATIONS")
- ◇ Run conduit to the Alarm Control Panel
- ◇ Connect conduit to the Alarm Control Panel and connect

Run cables AND AIRLINES

- ◇ Insert the 6-Hole Cord Seal into the 2" electrical couplings installed above
- ◇ Feed the cables and airlines from the tank through the 6-Hole Cord Seal to the junction box. Use the supplied plugs for any unused holes
- ◇ Tighten the nut on the Cord Seal with a 7/16" wrench to form a water/gas-tight seal around the cables and airlines
- ◇ Run wiring from the Alarm Control Panel to the junction box
- ◇ Make electrical and air connections inside the junction box, using the watertight connectors
- ◇ Insert desiccant in the completed box and mount the lid. Do not over-tighten screws when mounting the lid

Use electrical or plumbers' putty to seal and protect from moisture.

14. Effluent Discharge Pump Assembly and Installation (optional, Material Supplied by others)



PHOTO 33
INTERNAL MOUNTED JUNCTION BOX



PHOTO 34
EXTERNAL MOUNTED JUNCTION BOX

MicroSepTec does not supply pumps and pump discharge plumbing, as these vary widely by region. However, the EnviroServer can be ordered to accommodate discharge pumps. When ordered for pump controls, MicroSepTec will supply the panel, floats, Float Tree Assembly and Junction Box Assembly for pump controls. The following section is provided as a reference for the installation of a discharge pump. Local and state code along with regional best practices for installation should be followed when installing discharge pumps.

- ◊ Use a hole saw to cut a hole through the third man-way extension for installation of the Outlet Assembly (Photo 36)
- ◊ The high pressure pump uses 1" pipe and requires a 2" hole for the bulkhead fitting. The low pressure pump uses 1½" pipe and requires a 2¾" hole for the bulkhead fitting
- ◊ Attach the Bulkhead Outlet Assembly to the hole in the third riser drilled above

NOTE: When installing bulkhead fittings, 1) always install with rubber gasket inside the tank, as salts in the soil may break down the seal over time; and, 2) never turn the side with the O-ring, as it will force the O-ring out of shape so that the fitting won't seal.

- ◊ The pump will have a short nipple with a weep hole installed in its outlet. Thread the check valve onto this nipple, then glue the Straight Lengths of pipe together and into the male adapter installed in the check valve
- ◊ Install a hook on the inside of the third riser. This hook is used to attach the rope for pulling the pump in and out of the tank
- ◊ Attach the rope to the pump and use the rope to lower the pump into the fifth compartment without putting any strain on the plumbing joints
- ◊ Parts are supplied to route the piping in either of two ways: (1) outlet high in the riser and (2) low in the riser, depending on project needs and personal preference
- ◊ Dry-fit the Union Valve Assembly to the Bulkhead Outlet Assembly, as shown in the adjacent illustration, to determine the length of the vertical pipe attached to the pump
- ◊ Cut the vertical pipe attached to the pump so that the Union Valve Assembly can be attached to the Bulkhead Outlet Assembly
- ◊ Glue the Union Valve Assembly to the Bulkhead Outlet Assembly and to the vertical pipe attached to the pump, as shown in the adjacent illustration.
- ◊ Ensure the bulkhead fittings and unions are tightened
- ◊ The electrical cable for the pump will be connected in a junction box to be installed in the riser
- ◊ For duplex pump applications, repeat the above procedure

15. Float Installation

The system contains between one and four float switches, depending on the optional equipment selected at the time of order. The base gravity discharge system contains one High-Level Alarm float switch. Systems that the Pump Control Upgrade Kit has been ordered contain three additional float switches: On-Off Timer-Enable float, Peak Override float enable to override time dosing, and Redundant Off float switch to protect the pump from running dry.

FLOAT TREE MOUNTING BRACKET

NOTE: The Float Tree Mounting Bracket should be installed as high in the riser as possible, so the float tree is easily accessible for servicing (Photo 37).

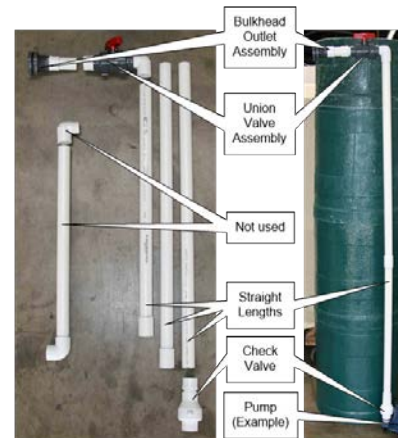

PHOTO 35
PUMP PLUMBING



PHOTO 36
CUTTING HOLE FOR DISCHARGE ASSEMBLY

INSTALLATION MANUAL

- ◇ The floats are installed on a float tree that is attached to a bracket in the third riser. Using the stainless steel nuts and bolts included, install the bracket in the third riser, over the final compartment, about 4" below the lid. Use a level to ensure it is plumb.
- ◇ Mount the supplied J-hook with included stainless steel nuts and bolts close to the Float Tree Mounting Bracket. This J-Hook is used to hold excess wire once float tree has been installed

NOTE: Float tree will rest on the pump platform located at the bottom of the effluent chamber

Installing floats on float holders

- ◇ Insert the end of the float cord through the face of the float holder starting from the lowest hole
- ◇ Pull cable through the center hole from the back of the float holder
- ◇ Push the cable back in through the top hole (Photo 38)
- ◇ Leave a 4" tether (from the Bottom of the float holder to the top of the float)
- ◇ Mark the float cable near the end with the float function of the float (e.g. High Level Float, Peak Override, ON/OFF Timer Enable, Redundant Off).

Installing float holders on Float tree

Note: All float locations will be measured from the bottom of the float tree.

Note: Measure and mark the position of the high level float before installing floats on float tree.

5' Diameter tanks 39" from the bottom

6' Diameter tanks 51" from the bottom

8' Diameter tanks 73" from the bottom

Note: If a discharge pump is used measure the height of the top of the motor or the inlet of the pump. Always keep the motor of a discharge pumped submerged the height of the top of the motor if a discharge pump

- ◇ **Redundant Off (optional):** Should be placed so when the float is down (activated) keeps the pump motor fully submerged.
 - ◇ Measure the distance from the bottom of the pump to the point in at which the pump motor will be protected according to the pump manufacturer's recommendations.
 - ◇ Add 5" to this measurement and mark that measurement on the float tree from the bottom of the float tree
 - ◇ Snap the float holder (with the float installed) (Photo 39) on the float tree, so that the middle of the float holder is centered on the mark made in the step above
- ◇ **On/Off Timer Enable:** Should be placed above the pump and/or the Redundant OFF Float and below the Peak Override Float. Tether length is determined by function. For demand-dosed systems the tether length is determined by dose volume needed. For timed-dosed systems the tether length is 4"
 - ◇ **Demand-Dosed**
 - ◇ Determine the dose volume needed, and estimate where the distance from the bottom of the tank to the off- point would be. Mark the float tree
 - ◇ Refer to MicroSepTec volume chart to determine the volume of each inch in the effluent compartment and determine the tether length needed to achieve the desired dose volume
 - ◇ Run the cables from any lower floats behind the float holder to hold the cables in place
 - ◇ Snap the float holder (with the float installed) on the float tree, so that the float holder is above the mark made in the step above.
 - ◇ **Timed-Dosed**



PHOTO 37
FLOAT TREE MOUNTING BRACKET INSTALLED
ON RISER

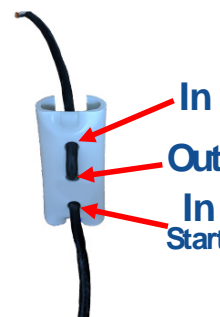

PHOTO 38
FLOAT MOUNTING TO FLOAT HOLDER

- ◇ The tether for timed-dose should be 4"
- ◇ On the float tree measure 4" above the top of the pump or 5" from the center of the Redundant Off Float Holder and mark the float tree.
- ◇ Run the cables from any lower floats behind the float holder to hold the cables in place
- ◇ Snap the float holder (with the float installed) on the float tree, so that the middle of the float holder is centered on the mark made in the step above.
- ◇ **Peak Override:** Should be between the High Level Float (marked on the float tree earlier in this section) and the On/Off Timer Enable Float. This float should have a 4" tether.
- ◇ Measure the distance between the center of the On/Off Timer Enable float and the High Level Float.
- ◇ Divide the distance in half and mark the float tree
- ◇ Run the cables from any lower floats behind the float holder to hold the cables in place
- ◇ Snap the float holder (with the float installed) on the float tree, so that the middle of the float holder is centered on the mark made in the step above.
- ◇ **High Level Float:** should have a 4" tether
- ◇ The position of this float was marked earlier in this section
- ◇ Run the cables from any lower floats behind the float holder to hold the cables in place
- ◇ Snap the float holder (with the float installed) on the float tree, so that the middle of the float holder is centered on the mark made in the step above.
- ◇ Rotate the float holders around the pipe to ensure floats do not interfere with other float operations
- ◇ Lower the float tree into the effluent storage chamber until the bottom of the float tree rests on the pump shelf at the bottom of the chamber
- ◇ Snap the float tree into the float tree Mounting Bracket
- ◇ Coil excess wire and hang on the J-hook



PHOTO 39
FLOAT HOLDER SNAPPED ON FLOAT TREE WITH WIRES BEHIND



PHOTO 40
FLOAT TREE WITH 3 FLOATS

16. Recirculation Installation

The recirculation pump (Photo 41) returns nitrified water and accumulated sludge from the fourth compartment (final clarifier) back to the first compartment (primary clarifier) for denitrification and sludge management. Standard EnviroServer systems are shipped with an airlift recirculation pump controlled either via a needle valve or solenoid valve.

Airlift Assembly and Installation

Needle Valve

- ◇ Standard systems include a needle valve control of the Airlift pump for recirculation
- ◇ For systems that require advanced treatment standard of $<30 \text{ mg/l CBOD}_{5r}$, $<30 \text{ TSS}$

Solenoid Valve

- ◇ Optional control of the Airlift pump for recirculation
- ◇ For system that require advanced treatment standards of $<30 \text{ mg/l CBOD}_{5r}$, $<30 \text{ mg/l TSS}$, and **Nitrogen reduction of greater than 50%**

If your system contains the optional mechanical recirculation pump, refer to the 'Mechanical Recirculation Pump Installation (Optional)' section for installation details. Ideally, this step will be completed once final grade is known and the risers are cut to the appropriate height.

Airlift Recirculation Pump Assembly Installation

- ◇ The Airlift Pump Assembly comes in two pieces (5' and 6' diameter tanks) or three pieces (8' diameter tanks) (Photo 41)
- ◇ Glue the two/three pieces together, as shown in the adjacent illustration.
- ◇ Connect the 1/4" airline previously feed through the sleeve (Step 4) from the second riser through the sleeve into the third riser and into the junction box
- ◇ Cut tubing to give approximately 6" of slack for the connection of the recirculation control valve
 - ◇ Mark this tubing as "IN"
- ◇ Run the remaining 1/4" tubing out of the junction box
 - ◇ Mark this tubing as "OUT"
- ◇ Connect 1/4" tubing marked as "OUT" to the bell end of the airlift pump
- ◇ Lower the airlift pump into position in the fourth chamber
 - ◇ The airlift assembly should extend to the bottom of the fourth chamber (Photo 42)

NOTE: When inserting tubing into quick-connect fittings, the tubing will stop when it reaches the internal O-ring; push past the O-ring (about another 1/4") to seal the connection.

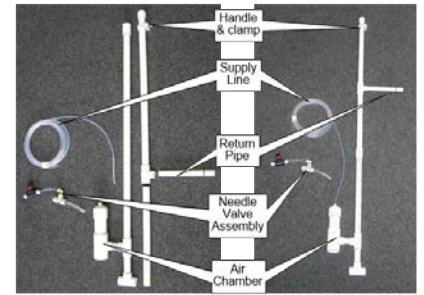

PHOTO 41
AIRLIFT RECIRCULATION PUMP ASSEMBLY

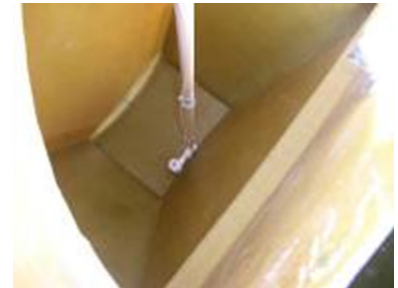

PHOTO 42
AIRLIFT RECIRCULATION INSTALLED

- ◊ Insert the ½" Return Pipe with the O-ring into the Recirculation Pipe located on the third baffle (fourth compartment) and accessed through the third manway (Photo 43)

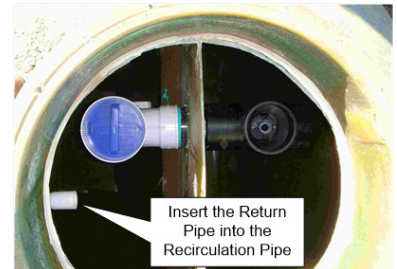

PHOTO 43

AIRLIFT ASSEMBLY CONNECTION POINT

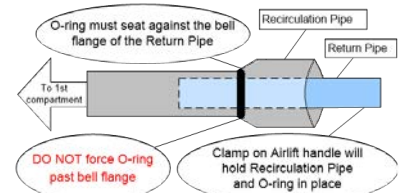

PHOTO 44

SEATED O-RING LOCATION

NOTE: The O-ring should be positioned so that it sits against the bell without going into the Recirculation Pipe and so that it will allow the handle to be clamped against the side of the riser (Photo 44)

DO NOT force the O-ring past flange created by the pipe bell.

- ◊ Make sure the airlift handle (the pipe that extends up in the riser) touches the riser wall so that the airlift pipe clamp can be installed (Photo 45)

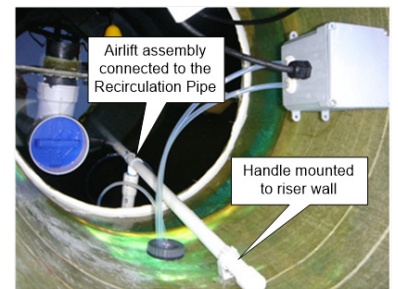

PHOTO 45

AIRLIFT ASSEMBLY CONNECTION POINT

- ◊ Mark the location for the clamp in the riser and remove the clamp from the pipe
- ◊ Use the attached stainless steel screws to secure the clamps to the riser wall (Photo 46)
- ◊ Secure the airlift assembly to the riser wall with the pipe clamp (Photo 47)
- ◊ Attach the assembly to the pipe clamps by pressing the pipe into the clamp
- ◊ **The clamp will automatically close around the pipe and lock**



PHOTO 46

CONNECT PIPE CLAMP TO RISER WITH 1" SCREW

NOTE: The airlift assembly should extend to the bottom of the fourth chamber or no more than one inch from the bottom.



PHOTO 47

PRESS PIPE INTO CLAMP

Mechanical Recirculation Pump Installation (Optional)

NOTE: This section applies only if you have the Mechanical Recirculation Pump (MRP) Option

Plumbing

The Electric Recirculation Pump Assembly installs in the fourth compartment of the tank and is routed to the clean-out installed in front of the tank in Step 1. The plumbing assembly and pump are shipped separately and require assembly. The procedure for installing the pump is identical to installing an discharge pump. Refer to 'Discharge Pump Assembly and Installation (Optional)' for instructions.

- ◇ Route the recirculation pipe from the exterior side of the Bulkhead Outlet Assembly back to the 4" x 1 1/2" sanitary tee in the clean-out installed in Step 1.

Electrical

- ◇ The electrical cable for the pump will be connected in a junction box that will be installed inside the third riser.
- ◇ The recirculation pump is powered by a timer relay located in the Alarm Control panel
- ◇ The directions for setting the timer for the Mechanical Recirculation Pump (MRP) can be found in the Technical Bulletin shipped with the Alarm Control Panel or in the Maintenance Manual.

17. Recirculation Valve and Pressure switch Connections

Recirculation Valve

The recirculation valve controls the amount of water recirculated back to the front of the system. The needle valve provides constant recirculation and can be adjusted with a knob on the top of the valve. The solenoid valve will be adjusted with a timer located in the Alarm Control Panel. Both the needle and solenoid valves are flow directional dependent, make sure the valve is installed to control the flow to the Airlift Pump (OUT)

- ◇ The recirculation valve will be installed in the junction box located in the third riser (Step 12)
- ◇ Connect the 1/4" airline marked "IN" (Step 15) into the inlet side of the recirculation valve
- ◇ Connect the 1/4" airline marked "OUT" (Step 15) into the outlet side of the recirculation valve going to the Airlift Pump

Pressure Switch Connections

1/4" tubing from the Air Supply fittings is routed to the pressure switches for monitoring the air pressure. This tubing was connected to the AIR SUPPLY INLET (Step 4) and ran through the sleeve to the third man-way.

- ◇ Run the 1/4" tubing to the junction box through the cord grip
- ◇ Insert the 1/4" tubing into the 1/4" quick-connect fitting(s) attached to the pressure switch(es)

NOTE: When inserting tubing into quick-connect fittings, the tubing will stop when it reaches the internal O-ring; push past the O-ring (about another 1/4") to seal the connection.

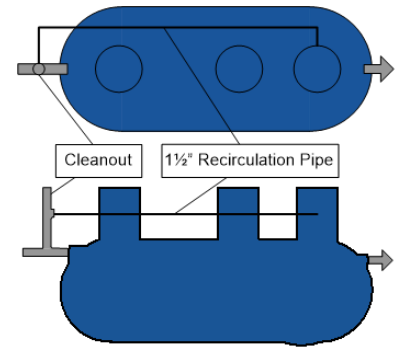

PHOTO 48
RECIRCULATION PIPE ROUTED TO THE CLEAN-OUT IN FRONT OF TANK



PHOTO 49
NEEDLE VALVE AND PRESSURE SWITCHES INSTALLED IN JUNCTION BOX



PHOTO 50
SOLENOID VALVE AND PRESSURE SWITCHES INSTALLED IN JUNCTION BOX

18. Effluent Filter Handle Installation

- ◊ If applicable, glue the effluent filter handle ($\frac{1}{2}$ " pipe section with $\frac{1}{2}$ " tee at one end) into the tee attached to the effluent filter cartridge (Photo 51)
- ◊ If applicable, insert the effluent filter handle ($\frac{1}{2}$ " pipe section with $\frac{1}{2}$ " tee at one end) into the opening on the top of the filter and use the stainless steel screws (included) to secure



PHOTO 51
ATTACH HANDLE TO EFFLUENT FILTER

19. Control Panel and electrical connections

- ◊ Mount the Alarm Control Panel controller in a secure location, on a vertical surface, any distance from the EnviroServer, preferably out of direct sunlight and at least 48" off the ground
- ◊ If Optional Telemetry will be included network cable is the preferred method of connection, ensure the Alarm Control Panel is within a distance that the network cable will not be ineffective
 - ◊ If Network Cable is not available and Wi-Fi will be used ensure the Alarm Control Panel is located with in line of site from the router with as few obstacles (e.g. walls) as possible to reduce interference.
- ◊ Run electrical conduit according to local and state code from the power source to the Alarm Control Panel

NOTE: Conduits leading to the Alarm Control Panel must include an explosion seal to prevent septic gases and moisture from entering the controller and corroding the components.



PHOTO 52
GRAVITY DISCHARGE ALARM CONTROL PANEL

CONDUIT TO ALARM CONTROL PANEL

- ◊ Use a hole saw to cut a $1\frac{5}{8}$ " hole in junction box where the conduit from the Alarm Control Panel will enter junction box
- ◊ Install the 1" male adapter, seal, and nut in the junction box
- ◊ Glue the junction box to the 1" conduit from the Alarm Control Panel

RUN CABLES AND AIRLINES

- ◊ Insert Cord Seal into the 2" electrical male adapter installed above
- ◊ Run the cables and airlines from the tank through the Cord Seal to the junction box. Use the supplied plugs for any unused holes
- ◊ Tighten the nut on the Cord Seal with a $\frac{7}{16}$ " wrench to form a water/gas-tight seal around the cables and airlines
- ◊ Run wiring from the Alarm Control Panel to the junction box
- ◊ Make electrical and air connections inside the junction box
- ◊ Insert desiccant in the completed junction box and mount the lid. Do not over-tighten screws when mounting the lid

Control Panel Installation

Electrical connections in the control panel will vary depending on the Alarm Control Panel being used.

- ◊ Refer to the Alarm Control Panel for all of the connections of for wiring diagrams.

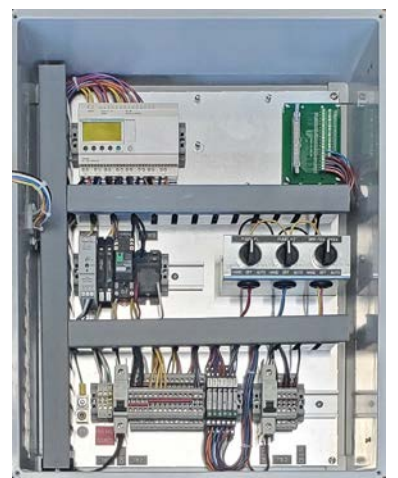

PHOTO 53
PUMPED DISCHARGE ALARM CONTROL PANEL

NOTE: Conduits leading to the Alarm Control Panel must include an explosion seal to prevent septic gases and moisture from entering the controller and corroding the components.

NOTE: Every Alarm Control Panel is shipped with a bag of desiccant to absorb any condensation and to prevent corrosion of components. Make sure the bag is still in the controller when installation is complete.

There is one option available for the Alarm Control Panel:

- ◇ Telemetry Option – for remote notification of alarm conditions

Telemetry is typically shipped pre-installed from the factory and wiring diagrams are included inside the controller to instruct how to make the necessary connections. If the Telemetry was not pre-installed at the factory when shipped it will have the necessary components and instructions for installation

20. Compressor Installation

Compressor location

- ◇ Compressors should be located in a well-ventilated, shady, accessible place. An indoor location like a shed or garage is ideal. Access should be made available for service if located in a shed or garage.
- ◇ Elevated off the ground so surface water cannot enter the electrical terminals of the compressor.
- ◇ Located as close to the tank as possible; do not exceed 50' distance from tank.
- ◇ Plumbing from compressor enters the middle riser
- ◇ The pipe must fall toward the tank with no low points.
- ◇ 1" Schedule 80 PVC pipe is required for plumbing the compressor(s) to the middle riser, one pipe per compressor

Placing the compressor

- ◇ There are several alternatives for the placement of the compressors (Photo 54 and Photo 55). In general, they should be on a steady, flat surface like concrete or brick. They should also be slightly elevated with respect to the ground so that surface water cannot enter the electrical terminals within the compressor.

Plumbing from the compressor

Refer to the adjacent illustration (Photo 56) for details about the plumbing. 1" Schedule 80 PVC pipe is required for plumbing the compressors to the middle riser, one pipe per compressor. The pipe must fall toward the tank with no low points, so that water cannot accumulate at any point in the plumbing. P-traps will create back pressure and will cause the compressor to fail prematurely.

- ◇ Mount the rubber boot and ½" compression fitting (shipped with the compressor) to the compressor outlet. Secure with the included clamp.
- ◇ Glue the 1" elbow with the attached ½" compression fitting to the 1" pipe. (Elbow, compression fitting, and tubing are included with the Air Supply Kit.)

NOTE: The 1" elbow with the attached ½" compression fitting must be installed above grade.

- ◇ Connect ½" tubing between the compressor and the compression fitting installed in



PHOTO 54

COMPRESSORS INSTALLED ON PAVERS



PHOTO 55

COMPRESSOR INSTALLED ON A SHELF

the elbow, using as little tubing as possible (two feet maximum).

NOTE: When inserting tubing into quick-connect fittings, the tubing will stop when it reaches the internal O-ring; push past the O-ring (about another ¼”) to seal the connection.

- ◊ The main run from the compressor to the tank must slope towards the top of the tank, or at least be level with the top.
- ◊ Do NOT go under obstacles and then back up in elevation, as this will create a water trap and decrease performance of the compressor.
- ◊ When making turns, use 45° elbows in lieu of 90° elbows; this is especially important when doing longer runs (pressure drop is lower in a 45° elbow).

NOTE: Make sure there is no dirt or debris in the pipe before gluing together, as this may inhibit or destroy the air supply system. If possible, used compressed air to blow any dirt out of the plumbing before making final connections.

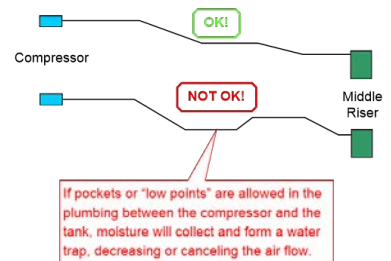
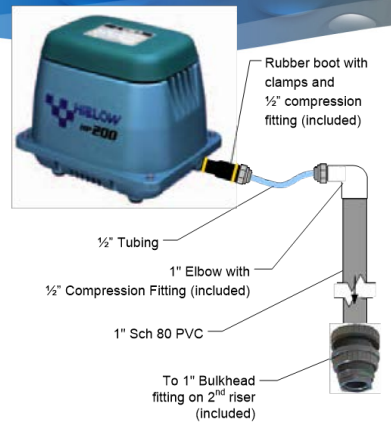

PHOTO 56
COMPRESSOR PLUMBING

21. Lid Installation

This step is to be completed once final grade is established and all other components are assembled and installed. It is critical that the lids, rings (if used) and risers are completely sealed to prevent water from flowing in, root intrusion and septic gases from escaping

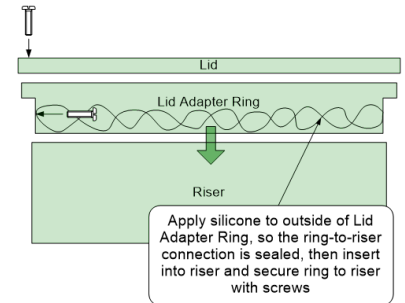

PHOTO 57
LID INSTALLATION

22. Sign Off

Every controller is shipped with an Owner’s Manual, “Installation Sign-Off Form”, and startup form. Remove the Sign-Off Form, verify all points on the checklist are complete, fill out the form, and submit it to MicroSepTec. The Owner’s Manual will be provided to the owner by the service provider at start-up.

NOTE: The Installation Sign-Off Form is REQUIRED to validate the warranty.

NOTE: System start-up must be completed by the service provider and is REQUIRED to Validate warranty. “Startup form” must be submitted to MicroSepTec for warranty validation.



Service provider information		Project information	
Company name _____	Job name _____	Address _____	City _____ State _____ Zip _____
Company contact _____	Company phone _____	Installer _____	Date of installation _____
Address _____	City _____ State _____ Zip _____		
City _____ State _____ Zip _____			
Date of start-up _____			
Base system		Optional equipment	
Check the appropriate boxes	Y/N	Y/N	Y/N
Inspected per MicroSepTec specifications	<input type="checkbox"/>	UV alarm works	<input type="checkbox"/>
Interior & exterior works	<input type="checkbox"/>	Backflow on float works	<input type="checkbox"/>
System is powered ON	<input type="checkbox"/>	Redundant off float works	<input type="checkbox"/>
Water leaks detected	<input type="checkbox"/>	Peak override float works	<input type="checkbox"/>
Air leaks detected	<input type="checkbox"/>	Sensored level MFP pump works	<input type="checkbox"/>
Test/valence switch operates	<input type="checkbox"/>	Pump OFF time _____ (seconds)	<input type="checkbox"/>
High level alarm works	<input type="checkbox"/>	Pump ON time _____ (seconds)	<input type="checkbox"/>
Low air alarm works (Group #1)	<input type="checkbox"/>	System is alarmed (Level) _____ (seconds)	<input type="checkbox"/>
Low air alarm works (Group #2)	<input type="checkbox"/>	Simplex effluent/discharge pump	<input type="checkbox"/>
Low air alarm works (Group #3)	<input type="checkbox"/>	Effluent/Discharge pump one work	<input type="checkbox"/>
Low air alarm works (Group #4)	<input type="checkbox"/>	Pump OFF time _____ (seconds)	<input type="checkbox"/>
Low air alarm works (Group #5)	<input type="checkbox"/>	Pump ON time _____ (seconds)	<input type="checkbox"/>
Low air alarm works (Group #6)	<input type="checkbox"/>	UV light works	<input type="checkbox"/>
Low air alarm works (Group #7)	<input type="checkbox"/>	UV light works	<input type="checkbox"/>
Low air alarm works (Group #8)	<input type="checkbox"/>	UV light works	<input type="checkbox"/>
Low air alarm works (Group #9)	<input type="checkbox"/>	UV light works	<input type="checkbox"/>
Low air alarm works (Group #10)	<input type="checkbox"/>	UV light works	<input type="checkbox"/>
Low air alarm works (Group #11)	<input type="checkbox"/>	UV light works	<input type="checkbox"/>
Low air alarm works (Group #12)	<input type="checkbox"/>	UV light works	<input type="checkbox"/>
Low air alarm works (Group #13)	<input type="checkbox"/>	UV light works	<input type="checkbox"/>
Low air alarm works (Group #14)	<input type="checkbox"/>	UV light works	<input type="checkbox"/>
Low air alarm works (Group #15)	<input type="checkbox"/>	UV light works	<input type="checkbox"/>
Low air alarm works (Group #16)	<input type="checkbox"/>	UV light works	<input type="checkbox"/>
Low air alarm works (Group #17)	<input type="checkbox"/>	UV light works	<input type="checkbox"/>
Low air alarm works (Group #18)	<input type="checkbox"/>	UV light works	<input type="checkbox"/>
Low air alarm works (Group #19)	<input type="checkbox"/>	UV light works	<input type="checkbox"/>
Low air alarm works (Group #20)	<input type="checkbox"/>	UV light works	<input type="checkbox"/>
Low air alarm works (Group #21)	<input type="checkbox"/>	UV light works	<input type="checkbox"/>
Low air alarm works (Group #22)	<input type="checkbox"/>	UV light works	<input type="checkbox"/>
Low air alarm works (Group #23)	<input type="checkbox"/>	UV light works	<input type="checkbox"/>
Low air alarm works (Group #24)	<input type="checkbox"/>	UV light works	<input type="checkbox"/>
Low air alarm works (Group #25)	<input type="checkbox"/>	UV light works	<input type="checkbox"/>
Low air alarm works (Group #26)	<input type="checkbox"/>	UV light works	<input type="checkbox"/>
Low air alarm works (Group #27)	<input type="checkbox"/>	UV light works	<input type="checkbox"/>
Low air alarm works (Group #28)	<input type="checkbox"/>	UV light works	<input type="checkbox"/>
Low air alarm works (Group #29)	<input type="checkbox"/>	UV light works	<input type="checkbox"/>
Low air alarm works (Group #30)	<input type="checkbox"/>	UV light works	<input type="checkbox"/>
Low air alarm works (Group #31)	<input type="checkbox"/>	UV light works	<input type="checkbox"/>
Low air alarm works (Group #32)	<input type="checkbox"/>	UV light works	<input type="checkbox"/>
Low air alarm works (Group #33)	<input type="checkbox"/>	UV light works	<input type="checkbox"/>
Low air alarm works (Group #34)	<input type="checkbox"/>	UV light works	<input type="checkbox"/>
Low air alarm works (Group #35)	<input type="checkbox"/>	UV light works	<input type="checkbox"/>
Low air alarm works (Group #36)	<input type="checkbox"/>	UV light works	<input type="checkbox"/>
Low air alarm works (Group #37)	<input type="checkbox"/>	UV light works	<input type="checkbox"/>
Low air alarm works (Group #38)	<input type="checkbox"/>	UV light works	<input type="checkbox"/>
Low air alarm works (Group #39)	<input type="checkbox"/>	UV light works	<input type="checkbox"/>
Low air alarm works (Group #40)	<input type="checkbox"/>	UV light works	<input type="checkbox"/>
Low air alarm works (Group #41)	<input type="checkbox"/>	UV light works	<input type="checkbox"/>
Low air alarm works (Group #42)	<input type="checkbox"/>	UV light works	<input type="checkbox"/>
Low air alarm works (Group #43)	<input type="checkbox"/>	UV light works	<input type="checkbox"/>
Low air alarm works (Group #44)	<input type="checkbox"/>	UV light works	<input type="checkbox"/>
Low air alarm works (Group #45)	<input type="checkbox"/>	UV light works	<input type="checkbox"/>
Low air alarm works (Group #46)	<input type="checkbox"/>	UV light works	<input type="checkbox"/>
Low air alarm works (Group #47)	<input type="checkbox"/>	UV light works	<input type="checkbox"/>
Low air alarm works (Group #48)	<input type="checkbox"/>	UV light works	<input type="checkbox"/>
Low air alarm works (Group #49)	<input type="checkbox"/>	UV light works	<input type="checkbox"/>
Low air alarm works (Group #50)	<input type="checkbox"/>	UV light works	<input type="checkbox"/>
Low air alarm works (Group #51)	<input type="checkbox"/>	UV light works	<input type="checkbox"/>
Low air alarm works (Group #52)	<input type="checkbox"/>	UV light works	<input type="checkbox"/>
Low air alarm works (Group #53)	<input type="checkbox"/>	UV light works	<input type="checkbox"/>
Low air alarm works (Group #54)	<input type="checkbox"/>	UV light works	<input type="checkbox"/>
Low air alarm works (Group #55)	<input type="checkbox"/>	UV light works	<input type="checkbox"/>
Low air alarm works (Group #56)	<input type="checkbox"/>	UV light works	<input type="checkbox"/>
Low air alarm works (Group #57)	<input type="checkbox"/>	UV light works	<input type="checkbox"/>
Low air alarm works (Group #58)	<input type="checkbox"/>	UV light works	<input type="checkbox"/>
Low air alarm works (Group #59)	<input type="checkbox"/>	UV light works	<input type="checkbox"/>
Low air alarm works (Group #60)	<input type="checkbox"/>	UV light works	<input type="checkbox"/>
Low air alarm works (Group #61)	<input type="checkbox"/>	UV light works	<input type="checkbox"/>
Low air alarm works (Group #62)	<input type="checkbox"/>	UV light works	<input type="checkbox"/>
Low air alarm works (Group #63)	<input type="checkbox"/>	UV light works	<input type="checkbox"/>
Low air alarm works (Group #64)	<input type="checkbox"/>	UV light works	<input type="checkbox"/>
Low air alarm works (Group #65)	<input type="checkbox"/>	UV light works	<input type="checkbox"/>
Low air alarm works (Group #66)	<input type="checkbox"/>	UV light works	<input type="checkbox"/>
Low air alarm works (Group #67)	<input type="checkbox"/>	UV light works	<input type="checkbox"/>
Low air alarm works (Group #68)	<input type="checkbox"/>	UV light works	<input type="checkbox"/>
Low air alarm works (Group #69)	<input type="checkbox"/>	UV light works	<input type="checkbox"/>
Low air alarm works (Group #70)	<input type="checkbox"/>	UV light works	<input type="checkbox"/>
Low air alarm works (Group #71)	<input type="checkbox"/>	UV light works	<input type="checkbox"/>
Low air alarm works (Group #72)	<input type="checkbox"/>	UV light works	<input type="checkbox"/>
Low air alarm works (Group #73)	<input type="checkbox"/>	UV light works	<input type="checkbox"/>
Low air alarm works (Group #74)	<input type="checkbox"/>	UV light works	<input type="checkbox"/>
Low air alarm works (Group #75)	<input type="checkbox"/>	UV light works	<input type="checkbox"/>
Low air alarm works (Group #76)	<input type="checkbox"/>	UV light works	<input type="checkbox"/>
Low air alarm works (Group #77)	<input type="checkbox"/>	UV light works	<input type="checkbox"/>
Low air alarm works (Group #78)	<input type="checkbox"/>	UV light works	<input type="checkbox"/>
Low air alarm works (Group #79)	<input type="checkbox"/>	UV light works	<input type="checkbox"/>
Low air alarm works (Group #80)	<input type="checkbox"/>	UV light works	<input type="checkbox"/>
Low air alarm works (Group #81)	<input type="checkbox"/>	UV light works	<input type="checkbox"/>
Low air alarm works (Group #82)	<input type="checkbox"/>	UV light works	<input type="checkbox"/>
Low air alarm works (Group #83)	<input type="checkbox"/>	UV light works	<input type="checkbox"/>
Low air alarm works (Group #84)	<input type="checkbox"/>	UV light works	<input type="checkbox"/>
Low air alarm works (Group #85)	<input type="checkbox"/>	UV light works	<input type="checkbox"/>
Low air alarm works (Group #86)	<input type="checkbox"/>	UV light works	<input type="checkbox"/>
Low air alarm works (Group #87)	<input type="checkbox"/>	UV light works	<input type="checkbox"/>
Low air alarm works (Group #88)	<input type="checkbox"/>	UV light works	<input type="checkbox"/>
Low air alarm works (Group #89)	<input type="checkbox"/>	UV light works	<input type="checkbox"/>
Low air alarm works (Group #90)	<input type="checkbox"/>	UV light works	<input type="checkbox"/>
Low air alarm works (Group #91)	<input type="checkbox"/>	UV light works	<input type="checkbox"/>
Low air alarm works (Group #92)	<input type="checkbox"/>	UV light works	<input type="checkbox"/>
Low air alarm works (Group #93)	<input type="checkbox"/>	UV light works	<input type="checkbox"/>
Low air alarm works (Group #94)	<input type="checkbox"/>	UV light works	<input type="checkbox"/>
Low air alarm works (Group #95)	<input type="checkbox"/>	UV light works	<input type="checkbox"/>
Low air alarm works (Group #96)	<input type="checkbox"/>	UV light works	<input type="checkbox"/>
Low air alarm works (Group #97)	<input type="checkbox"/>	UV light works	<input type="checkbox"/>
Low air alarm works (Group #98)	<input type="checkbox"/>	UV light works	<input type="checkbox"/>
Low air alarm works (Group #99)	<input type="checkbox"/>	UV light works	<input type="checkbox"/>
Low air alarm works (Group #100)	<input type="checkbox"/>	UV light works	<input type="checkbox"/>
Service provider's name (printed): _____	Signature: _____		

Limited Warranty

NOTE: The MicroSepTec Installation Form and Startup Form must be completed upon installation of the system and components, and submitted to MicroSepTec to initiate manufacturer's warranty. These forms verify that the system was installed according to manufactures recommendations, that the system was started properly, and according to manufactures recommendations. In the case that an Authorized Installer also performed the startup of the system, the Startup Form will satisfy the warranty paperwork requirements. It is highly recommended that copies of these forms are accompanied with pictures of major components installation to ease the warranty submission process as proof of correct installation, should there ever be a need for warranty claims. A copy of these forms is shipped with each system or can be obtained from your local EnviroServer Distributor or by contacting MicroSepTec.

Additionally, inspections must be completed bi-annually, and inspection forms submitted to MicroSepTec for the initial two years of service in order to continue validation of warranty. Ongoing maintenance is recommended after the initial two year warranty period and in some areas may be required by local regulations. The frequency of maintenance needed should be established by your service provider, be determined according to system use, the components of the system, and local jurisdictional code.

MicroSepTec EnviroServer ES Series

What is covered: MST Manufacturing, Inc. ("MST") warrants the parts in each EnviroServer Advanced Treatment System to be free from defects in material and workmanship for a period of two years from the date of initial installation as evidenced by the installer's Installation Sign-Off Form, or three years from date of sale, whichever occurs first. In order to activate warranty Installation Form, and Startup Form must be submitted to MST. The absence of an Installation Form with a completed Startup form will validate the warranty

What MST will do to correct problems: MST's sole obligation under this warranty is to fulfill this warranty by repairing or exchanging, at the sole discretion of MST, any component part, F.O.B. factory, that, in MST's judgment, shows evidence of defects – provided said component part has been paid for and is returned through an authorized dealer or distributor, delivery charges prepaid, along with proof of the date of original purchase, date of installation sign-off, and a written statement from the warranted specifying the nature of the defect.

What this warranty does not cover: This warranty covers only normal residential use within the United States. MST cannot warranty the treatment performance of the system since it cannot predict or control the nature of the influent and the effect of the influent on the biological process. MST is not responsible for warranty service should the MST label, the rating label, or serial number be removed or should the product fail to be properly maintained or fail to function properly as a result of misuse, abuse, improper installation, neglect, improper shipping, damage caused by disasters such as fire, flooding by external means, lightning, improper wiring or electrical current, interaction with non-MST products, service other than by a MST Authorized Service Provider, or the introduction of hazardous or harmful materials into the system.

This warranty applies only to the EnviroServer and does not include parts and components not supplied by MicroSepTec although they may be installed within the MicroSepTec EnviroServer System. These components include but are not limited to the chlorine tablets or UV lamp, if applicable, or any of the existing on-site wiring, plumbing, venting, drainage, or additional disposal system components. In addition to, and not in limitation of anything else contained in this warranty, MST is not responsible for any delay or damages caused by defective components or material, or for loss incurred because of interruption of service, or for any other special or consequential damages or incidental expenses arising from the manufacture, sale, or use of the EnviroServer.

The EnviroServer wastewater treatment system is based on a biological process using natural bacteria and oxygen to efficiently digest the waste in the water. The following items are examples of substances that should never be introduced into an on-site system because they can overtax or destroy the biological digestion or clog pumps and pipes and constitute misuse and/or abuse of the system: water softeners; excessive amounts of fat, grease or oil; coffee grounds; disposable diapers; feminine hygiene products; condoms; cigarette butts; gauze or adhesive bandages; cotton swabs; dental floss; cat litter; excessive amounts of disinfectants, detergents & cleaning supplies; chemicals, such as paints, varnishes, thinners, oils, photographic solutions, pesticides; construction debris; and prescription medicines.

MST reserves the right to revise, change, or modify the construction and design of the EnviroServer or any component part or parts thereof without incurring any obligation to make such changes or modifications in previously manufactured equipment. MST also reserves the right, in making replacements of component parts under this warranty, to furnish a component part which, in its judgment, is equivalent to the part being replaced. In addition to, and not in limitation of anything else contained in this warranty, under no circumstances will MST be responsible for any other direct or consequential damages, including (but not limited to) lost profits, lost income, labor charges, delays in production, and/or idle production, which result from defects in material and/or workmanship of the EnviroServer.

THIS WARRANTY AND REMEDY PROVIDED ABOVE ARE EXCLUSIVE AND IN LIEU OF ALL OTHER EXPRESS WARRANTIES AND, UNLESS STATED HEREIN, ANY STATEMENTS OR REPRESENTATIONS MADE BY ANY OTHER PERSON OR FIRM ARE VOID. THE DURATION OF ANY IMPLIED WARRANTIES OF MERCHANTABILITY OR FITNESS FOR A PARTICULAR PURPOSE ON YOUR ENVIROSERVER SYSTEM SHALL BE LIMITED TO THE DURATION OF THE EXPRESS WARRANTY SET FORTH ABOVE. EXCEPT AS PROVIDED IN THIS WRITTEN WARRANTY, NEITHER MICROSEPTEC NOR ITS AFFILIATES SHALL BE LIABLE FOR ANY LOSS, INCONVENIENCE, OR DAMAGE INCLUDING DIRECT, SPECIAL, INCIDENTAL, OR CONSEQUENTIAL DAMAGES RESULTING FROM THE USE OR INABILITY TO USE THE ENVIROSERVER, WHETHER RESULTING FROM BREACH OF WARRANTY OR ANY OTHER LEGAL THEORY